

Roco

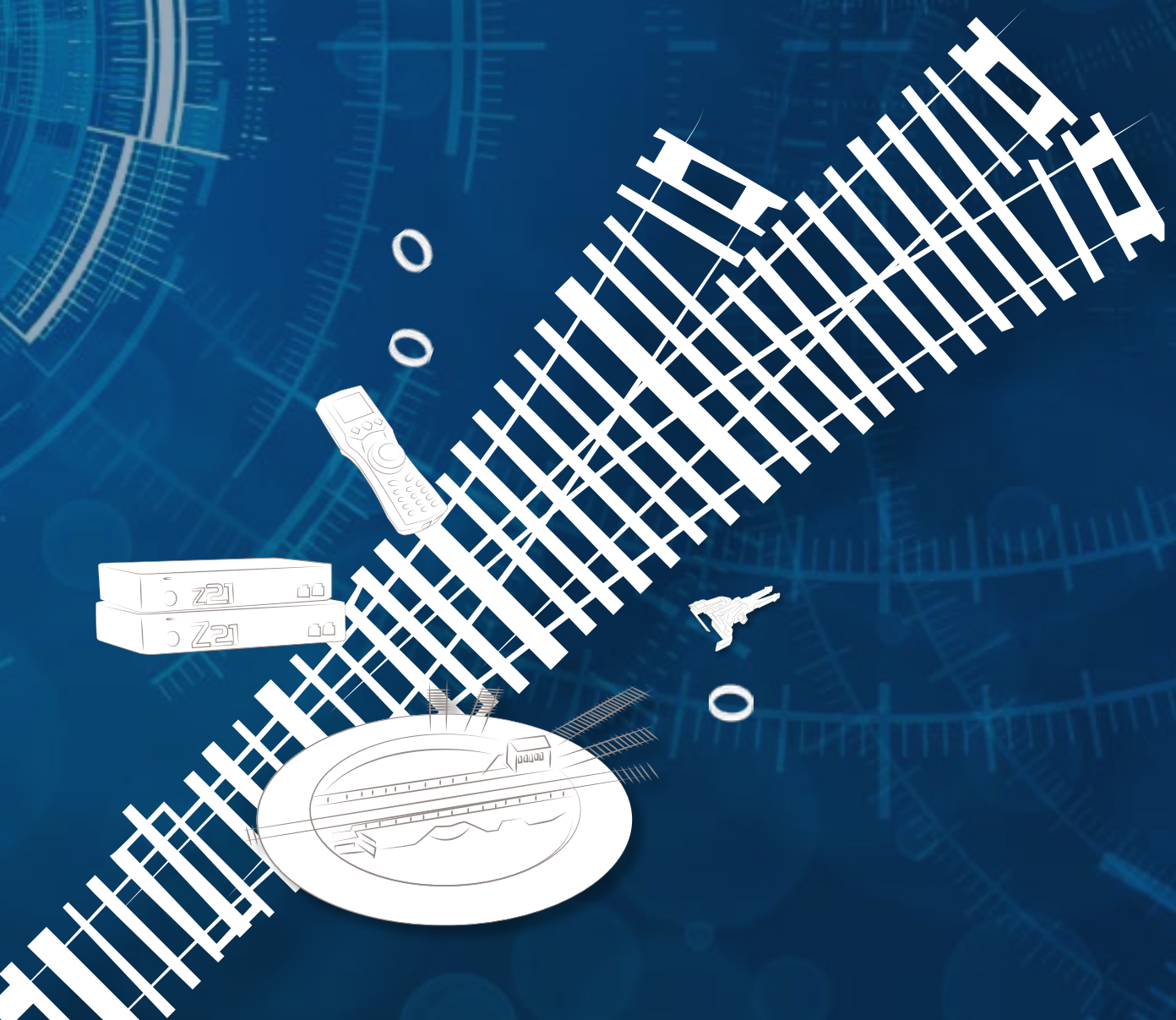

2022 Accessories

Great in detail and technology

www.roco.cc





Contents

Digital system	5
Decoder	18
General accessories	20
Lightings	24
Couplings	25
Wheel Sets	28
Tracks	33
ROCO LINE with bedding	38
ROCO LINE flex tracks	45
ROCO LINE without bedding.....	46
Track accessories	54
H0e tracks	58
TT accessories	60
Books	62
Where do I find what?	64



Dear ROCO fans,

in addition to perfectly detailed models which also impress with optimal operating characteristics, a model railway layout needs one thing in particular: Accessories! For this reason, our comprehensive catalogue contains the entire ROCO Accessories product range.

This includes, amongst other things, our popular Z21 system. An intuitive digital control system that has already convinced tens of thousands of users worldwide. Convince yourself of the diverse expansion possibilities and become a Z21 fan too!

You will also obtain an overview of our ROCO LINE track system, which is available either with an authentic ballast bed replica made of soft rubber, or without a bedding. Due to the generously-dimensioned geometry, all your track plan desires can be fulfilled.

This catalogue provides you with the perfect overview. However, should you still have questions, our Customer Service Team will be happy to advise you directly. And your specialist retailer is also happy to advise you!

We wish you much enjoyment during the creation of your great little world.

Your ROCO team



DIGITAL



All advantages at one glance

- ▶ Wireless controlling via tablet, smartphone, and the Z21 WLANMAUS
- ▶ High-capacity administration for a large rolling stock (up to 9,999 locomotive and 2,048 turnout addresses)
- ▶ Open multi-protocol centre supporting DCC and Motorola™ formats
- ▶ Upgrade for already existing digital layouts through downwards-compatibility, i.e. Z21 multiMAUS, Lokmaus 2, multiMAUS^{PRO} etc.
- ▶ Read out values and get feedback of locomotives and switches via RailCom*
- ▶ Save and reload locomotive data with the import and export function
- ▶ Possibility to update software & sound of ZIMO sound decoders

Z21 system

z21 start

Available in start set



without z21 WiFi package

in combination with
z21 WiFi package

10814/10818



z21

Available in start set



incl. WiFi router

Z21

10820



incl. WiFi router

Z21 XL Series

10870



incl. WiFi router

Plug & play system	<input checked="" type="checkbox"/>	<input checked="" type="checkbox"/>	<input checked="" type="checkbox"/>	<input checked="" type="checkbox"/>	<input checked="" type="checkbox"/>
2 X-Bus ports on the front	<input checked="" type="checkbox"/>	<input checked="" type="checkbox"/>	<input checked="" type="checkbox"/>	<input checked="" type="checkbox"/>	<input checked="" type="checkbox"/>
1 X-Bus ports on the back	<input type="checkbox"/>	<input type="checkbox"/>	<input type="checkbox"/>	<input checked="" type="checkbox"/>	<input checked="" type="checkbox"/>
DCC & MM	<input checked="" type="checkbox"/>	<input checked="" type="checkbox"/>	<input checked="" type="checkbox"/>	<input checked="" type="checkbox"/>	<input checked="" type="checkbox"/>
POM programming, POM reading, CV programming and CV reading	<input checked="" type="checkbox"/>	<input checked="" type="checkbox"/>	<input checked="" type="checkbox"/>	<input checked="" type="checkbox"/>	<input checked="" type="checkbox"/>
B-Bus and R-Bus	<input checked="" type="checkbox"/>	<input checked="" type="checkbox"/>	<input checked="" type="checkbox"/>	<input checked="" type="checkbox"/>	<input checked="" type="checkbox"/>
Configurable with the Maintenance Tool	<input checked="" type="checkbox"/>	<input checked="" type="checkbox"/>	<input checked="" type="checkbox"/>	<input checked="" type="checkbox"/>	<input checked="" type="checkbox"/>
Regulation with comfortable Z21 app and diverse hand held controller	<input type="checkbox"/>	<input checked="" type="checkbox"/>	<input checked="" type="checkbox"/>	<input checked="" type="checkbox"/>	<input checked="" type="checkbox"/>
Photorealistic driver's cab on Android tablet and iPad	<input type="checkbox"/>	<input checked="" type="checkbox"/>	<input checked="" type="checkbox"/>	<input checked="" type="checkbox"/>	<input checked="" type="checkbox"/>
LocoNet and sniffer Bus port	<input type="checkbox"/>	<input type="checkbox"/>	<input type="checkbox"/>	<input checked="" type="checkbox"/>	<input checked="" type="checkbox"/>
CAN Bus - allows comfortable configuration of new Z21 components	<input type="checkbox"/>	<input type="checkbox"/>	<input type="checkbox"/>	<input checked="" type="checkbox"/>	<input checked="" type="checkbox"/>
Adjustment options for track voltage	<input type="checkbox"/>	<input type="checkbox"/>	<input type="checkbox"/>	<input checked="" type="checkbox"/>	<input type="checkbox"/>
Separate programming track output with Zimo decoder update process	<input type="checkbox"/>	<input type="checkbox"/>	<input type="checkbox"/>	<input checked="" type="checkbox"/>	<input checked="" type="checkbox"/>
Gauges	N – H0	N – H0	N – H0	N – H0	0 – 2

Z21 digital control centre

10820

10822 US version

The Z21 digital control centre connects your model railway system, your digital locomotives and wagons via WiFi to your tablet, smartphone or the Z21 wlanMAUS. No additional networking knowledge is needed for this. You can extend your Z21 digital control centre easily due to the large number of interfaces. This also makes it the ideal basis for PC-based automation.

Content:

- 1 Z21 digital control centre
- 1 switching power supply (10851)
- 1 pre-configured WiFi router for Plug & Play operations incl. switching power supply
- 3 back plug terminal RM3,5 2p



Z21 multiMAUS

10835

The Z21 multiMAUS is a digital control centre that enables you to control your trains, use digital functions, switch turnouts and signals and much more. The clear design in combination with easy operation handling makes the Z21 multiMAUS a benchmark in the field of digital model train control systems and not just for digital beginners. Digital professionals also can profit from a large variety of advanced functions so that they can drive their locomotives absolutely true to the originals.



Possibilities

- ▶ 64 locomotives with 5 digits names
- ▶ Up to 29 functions can be activated per locomotive
- ▶ Up to 1,024 magnetic items switchable
- ▶ Write and read configuration variables (DCC CVs)

Z21 wlanMAUS

10813

Control unit with many operation functions. Several Z21 wlanMAUS can be simultaneously operated – possible with all Z21 systems (z21 start combined with WiFi package 10814, 10818). The Z21 wlanMAUS gives you wireless freedom around your layout.

The Z21 wlanMAUS also offers:

- ▶ Wireless freedom through WiFi transmission
- ▶ 29 functions per locomotive
- ▶ 100 locomotive addresses can be stored in the database and can be assigned with names (up to 10 digits)
- ▶ Operated with commercially available standard batteries (3 x AAA, not included in the delivery)
- ▶ Up to 2,048 magnetic items switchable

Z21

www.z21.eu

z21 start base digital set

10833

Content:

- 1 z21 start digital control centre
- 1 Z21 multiMAUS
- 1 plug-in power supply



Z21 professional digital set

10834

Content:

- 1 Z21 digital control centre
- 1 WiFi router
- 1 Z21 wlanMAUS
- 1 plug-in power supply



The **z21 start** offers everything needed to get started immediately:

- ▶ Digital controlling of locomotives and simple reading and programming with the Z21 multiMAUS.
- ▶ Possible connection of several Z21 multiMAUS devices (for parallel controlling of several locomotives).
- ▶ Prepared for WiFi

z21 WiFi package

10814

The z21 WiFi package contains a preconfigured router and the activation code for the z21 start. This way the z21 start can accept commands for locomotives and turnouts via the WiFi interface and process them. System requirement is a Windows PC or notebook as well as an existing Internet connection.

FOR z21 start



z21 unlock code

10818

The z21 activation code is required if you already have your own router. Please note that extended network knowledge is necessary for this purpose.

FOR z21 start



Z21 XL Series digital control centre

The new Z21 XL series has been especially adapted for the requirements of large gauges (0, 1, 2, G), and unites the advantages and the convenience of the Z21 system with high output voltages.

10870

- ▶ More output voltage with 6 A at 20 V
- ▶ Control via WiFi provides high range and transmission security
- ▶ Convenient Z21 App and Z21 WLANMAUS for the control of your entire system

Content:

- 1 Z21 XL Series digital control centre
- 1 Plug-in power supply and cable 6 A, 20 V
- 1 WiFi router & plug-in power supply



Z21 XL BOOSTER

10869

- ▶ Output voltage 6 A at 20 V
- ▶ Track format DCC and Motorola**
- ▶ B-BUS
- ▶ CAN-BUS
- ▶ CDE interface
- ▶ RailCom* receiver and transmission to control centre (CAN)
- ▶ Forwarding of short-circuits to control centre (adjustable)
- ▶ Firmware update (CAN)
- ▶ RailCom* cut-out adjustable

10857

Suitable power supply 120 W (see page 14)



10836

Z21 switch DECODER

The Z21 switch DECODER is an universally applicable DCC switching decoder with a power output of 2 Amperes for up to 8 turnouts or up to 16 elements such as LEDs and bulbs.

Adjustable outputs

Each of the 8 output pairs can be set to different modes independently of the other. These are already pre-configured and can simply be selected. Each output pair can also be individually dimmed so that lighting can be adapted precisely to requirements.

It perfectly can be combined with:

- ▶ Twin coil motors
- ▶ Simple light signals
- ▶ All kind of illumination
- ▶ Control of relays

Highlights:

- ▶ 8 output pairs can be set independently
- ▶ Optional power supply via extra applied switching power supply
- ▶ Programmable with RailCom* on the main track (POM)
- ▶ Short-circuit protection against overload
- ▶ Updateable



10837

Z21 signal DECODER

The Z21 signal DECODER is a universally applicable DCC decoder for complex light signals. Operation is even easier with the Z21 app as the signal types are also stored in the app and can be read out automatically from the decoder. This can be conveniently done via Z21 pro LINK.

- ▶ Updateable
- ▶ Extensively configurable
- ▶ RailCom* compatible

Over 30 signal types are included, such as:

- ▶ **Germany:** H/V signals, Ks signals, HI signals, block signals, ...
- ▶ **Austria:** Main signals class 1980 and 1954, pre-signals, protections signals, ...
- ▶ **Switzerland:** System L, system N, Signals for shunting service, ...

Additional signal types can of course be added by using the update function via the Z21 pro LINK.



10838

Z21 pro LINK

The configuring and networking of your Z21 hardware is getting even simpler and more convenient. In addition the Z21 pro LINK also stands out thanks to easy operation and the ability to keep up to date with updates.

Configuration and networking of your Z21 components at a new level:

- ▶ No complex CV tables
- ▶ With integrated web server
- ▶ Installed WiFi

The 3 essential functions:

1. Configuring

The Z21 pro LINK always automatically detects which device it is currently connected to. You can conveniently configure this device via the installed display and buttons without the need of any other components. Or you carry out the necessary adjustments via Z21 pro LINK website on your PC or smartphone.

2. Updating

Always keep your Z21 system up to date and benefit permanently from all new functions. You can perform this easily with the Z21 Updater App for iOS and Android or via PC with the Z21 Maintenance Tool.

3. Controlling

The Z21 pro LINK also networks all of your devices with zLink interface. It enables to perform communication with control commands and status queries directly via WiFi. Therewith the „Internet of Moba Things“ has become reality.

Here the link to the video:
Z21 pro LINK in action







10805

Z21 light BOOSTER

- ▶ Power 3 A (track output)
- ▶ RailCom* cutout (allows use of RailCom*-track occupied detector)
- ▶ Terminal loop feature with short-circuit detector
- ▶ Connection via B-Bus



10806

Z21 single BOOSTER

- ▶ Power 3 A (track output)
- ▶ Adjustable track voltage (12 V–24 V)
- ▶ RailCom* global detector
- ▶ Terminal loop feature with short-circuit detector
- ▶ Brake generator feature configurable
- ▶ Connections via CAN-Bus, B-Bus, CDE-Bus
- ▶ Configuration and update simply by PC via CAN



10807

Z21 dual BOOSTER

- ▶ Power 2x 3 A (track outputs)
- ▶ Voltage can be set for both track outputs separately via app or PC via Z21 (12–24 V)
- ▶ RailCom* global detector
- ▶ Terminal loop feature can be separately configured by means of short-circuit detector
- ▶ Brake generator feature can be separately configured for both
- ▶ Connections via CAN-Bus, B-Bus, CDE-Bus
- ▶ Configuration and update simply by PC via CAN



10804

Z21 CAN HUB

- ▶ Additional 2 A power supply for CAN-Bus
- ▶ 3 CAN outputs
- ▶ 1 Z-CAN output with booster signal amplification
- ▶ Ideal for large track layouts with many CAN users
- ▶ Including a connecting cable for CAN-Bus

10851

Suitable power supply 54 W (see page 14)

10851

Suitable power supply 54 W (see page 14)

10857

Suitable power supply 120 W (see page 14)

10850

Suitable power supply 36 W (see page 14)

Z21 DETECTOR

10808



- ▶ Track-occupied detector for 8 sections
- ▶ Occupied message by means of power monitoring of track sections
- ▶ RailCom* detector for loco identification
- ▶ Connection via CAN-Bus and R-Bus
- ▶ Configuration via button or CAN

Z21 DETECTOR x16

10819



- ▶ Track occupancy sensor for 16 track sections
- ▶ Occupied signal is triggered by the power monitoring of the track sections
- ▶ Connection via R-Bus
- ▶ Configuration via buttons or POM CV programming

Z21 multi LOOP

10797



- ▶ Ideal for terminal loops, triangular junctions and turntables
- ▶ Compatible with RailCom*
- ▶ Operated by short-circuit detector, switching contacts or sensor tracks
- ▶ Compatible with DCC, MM and analogue mode



10789

Z21 CDE booster adapter

The booster adapter is used to facilitate connection of up to 15 Boosters with CDE ports to the Boosterbus. To supply the adapter with voltage, there is an X-BUS connection. Status LEDs display the 12 V supply as well as an active CDE output stage, and the adapter also has overcurrent and short circuit shut-down protection on the CDE output.

The booster adapter can be used on the following central units or amplifiers:

Digital amplifier (10764), multiZENTRALE^{pro} (10832) and z21, z21 start as well as Z21 (10820, 10822).



10859

USB switching power supply 5 watts

Ideal for Z21 pro LINK. With USB-A to Micro-USB-B cable.



10850

Switching power supply 36 watts

Ideal for Z21 CAN HUB and z21 start.

Output voltage: 18 V =

- Protection against:
Overload, short circuit, over-tension



10851

Switching power supply 54 watts

Ideal for Z21, z21, Z21 single BOOSTER, Z21 light BOOSTER.

- Protection against:
Overload, short circuit, over-tension

Technical data:

Input voltage: 230 V ~
Output voltage: 20 V =
Output current: 3 A



10857

Switching power supply 120 watts

Ideal for Z21 dual BOOSTER und Z21 XL BOOSTER.

- Protection against:
Overload, short circuit, over-tension, over-temperature

Technical data:

Input voltage: 100–240 V ~
Output voltage: 20 V =
Output current: 6 A



96341

Power supply 40 watts Meanwell (USA & AUSTRALIA)

Ideal for z21, z21 start and Z21 CAN HUB.

- Protection against:
Overload, short circuit, back feed



96342

Power supply 90 watts (USA & AUSTRALIA)

Ideal for Z21, smart RAIL, Digital amplifier, Z21 switch DECODER, Digital booster, z21 start, Z21 single BOOSTER, Z21 light BOOSTER and the multiZENTRALE^{pro}.

- Protection against:
Overload, short circuit, over-tension, over-temperature

Connection cables for digital components

10754



Highly flexible 6-pole spiral cable

Connection between Z21 multiMAUS (10835, 10810) and 10820, 10822, 10815, 10764. Suitable for the FLEISCHMANN multiMAUS from digital start sets. Length approx. 2 m

10756



6-pin data bus replacement cable

Replacement cable for Z21 multiMAUS (10810), Lokmaus (10760, 10792), turnout keyboard (10770) or RouteControl (10772). It cannot be used to extend connector cables for Lokmaus 1 (Item no. 10750). Length approx. 2 m

10753



CAN BUS Cable

For connecting Z21 CAN devices. Length approx. 2 m

136100



Z21 Loconet Slave cable

A special cable that allows to use the Z21 as Loconet Slave on another central control unit.

10757



Booster connection cable

Spare cable for connecting boosters (10765, 10789, 10805, 10806, 10807) with:

- ▶ Digital amplifier (10764)
- ▶ Digital central power unit (10820, 10822, z21)
- ▶ Brake generator (10779)
- ▶ Connecting the boosters mentioned above among each other

10758



4-pin data bus distributor module

To connect further input units (for example Lokmaus or Z21 multiMAUS). This distributor module can also be used as an extension of existing lines to units on the slave output.
Note: The cable of the Master Lokmaus should not be extended in order to avoid impairing the quality of the data transmission.

Z21

www.z21.eu

More information about Z21 model railway control, Z21 app, updater app, maintenance tool such as schematic signal box etc. you can find on our website, in the Z21 brochure and from your specialist retailer.



Z21 operating mode

The Z21 digital control centre connects your railway system and your digital locomotives with your tablet and smartphone via WiFi.

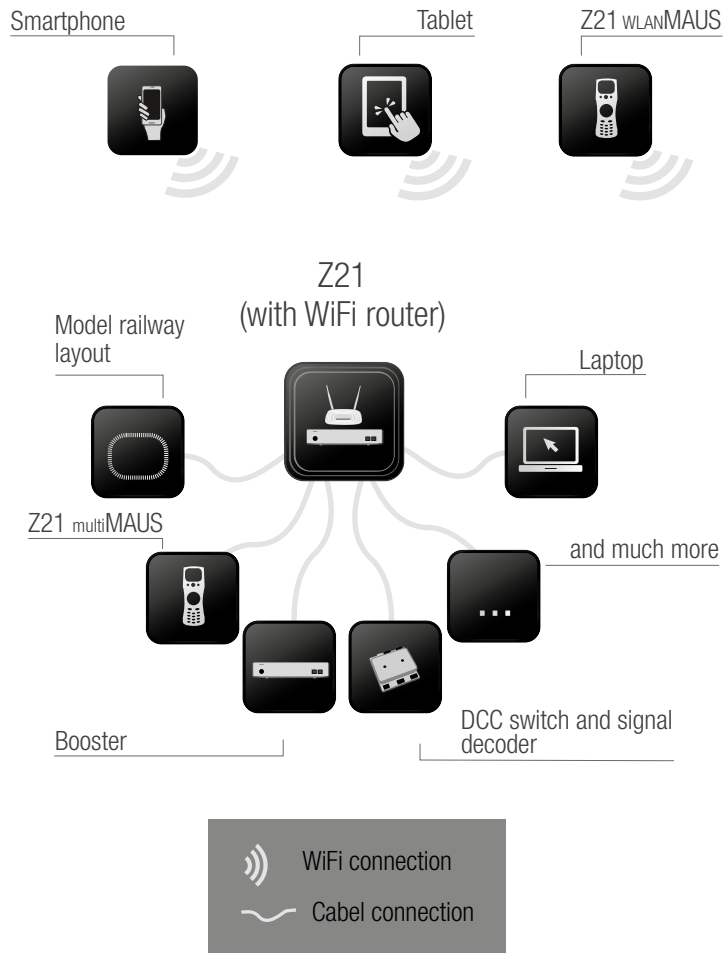

The Z21 system is compatible with many well-established PC-based model railway controllers. Furthermore the system is perfectly suited to control your garden railway.

Z21 app

The Z21 app allows you to create a detailed library of locomotives. Here you can easily add all locomotive-specific data, as well as main control information. In addition the Z21 system also supports automatic synchronisation with multiple input devices.

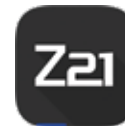

**Download in the app Store for iOS
or in the Google Play Store for Android!**

The app is available as a free download and can also be tested without using a Z21 system.

Here the link to the video:
Z21 app tutorial - controlling



Photorealistic driver's cab

Converting or upgrading to digital model railways will reward you with many advantages.

To be able to drive the locomotives as the driver himself is just one of the features which will make your eyes light up. As the locomotive driver, be amazed by the photorealistic views of the driver's cabs, which are equipped with original switches, controls from the relevant locomotive model, and interactive functions. Every control-related button and lever can be selected and provides the relevant action for your locomotive model. The Z21 app covers 8 individual driver's cabs starting with the driver's cab of the ETA 150 up to the Re 4/4, which are just waiting to be controlled by you. Because digital locomotive driving also needs practice to achieve mastery.

Please note that the driver's cabs are only available on iOS and Android devices.

Driver's cab of the ETA 150/class 515



- 1 Speed display
- 2 Traction current and battery current display
- 3 Speed step switch to set up and speed up
- 4 Brake lever
- 5 Door controls for opening and closing
- 6 Operational function keys

Driver's cab of the Re 4/4



- ① Main switch
- ② Locomotive brake
- ③ Car brake
- ④ Direction switch
- ⑤ Whistle
- ⑥ Emergency stop
- ⑦ Train headlight
- ⑧ Fan
- ⑨ Pantograph
- ⑩ Brake line pressure

Here the link to the video:
Z21 app tutorial - driver's cab



Speaker set

10889



With this speaker set you can retrofit any sound. Complete set with sound box and connection cables.

Dimensions: 10 x 15 x 9 mm



The new generation of feedback decoders

The characteristics of the locomotive decoders 10894, 10895 and 10896:

Advanced reset and protection functions; all outputs are short-circuit proof. Overcurrent protection for motor and function outputs by switching off and automatic restart. DC and AC analogue operation, with optional unregulated or load-sensing motor control. Software update capability via Z21 (An update via the z21 from the starter sets is not possible). Low-noise motor control, suitable for all kinds of DC and bell-type armature motors. Full NMRA function mapping with enhancements; Dimming, flashing, high beam / low beam switchover via function key. Time limit of the coupler control for overload protection (ROCO-Digi-coupling). Support of braking distances; Locomotive addresses are programmable; Comfortable change of the operating parameters, so the loco does not have to be opened.

The characteristics of the sound decoders 10890, 10891, 10892 and 10893 (can be used in addition to the loco decoders):

Powerful sound amplifier. Acceleration and load dependency of sound reproduction. Loading of sound projects is possible.

Detailed technical information about the decoders can be found in the operating instructions as well as on:

www.zimo.at

6-pin decoder (NEM 651)

10887



6-pin decoder, angled pins; can be updated; multiprotocol operation possible; motor control; braking tracks supported; locomotive addresses programmable; comfortable change of operating parameters possible: i.e. the locomotive does not have to be opened; overcurrent protection; RailCom*

Suitable for Gauge H0e, TT and N.

Technical data:

- ▶ DCC + RailCom*, DC analogue, MM, AC analogue
- ▶ Dimensions: 13 x 9 x 2.6 mm
- ▶ 0.7 A motor, total (peak 1.5 A)
- ▶ 6 function outputs
- ▶ 4 outputs for additional functions

Corresponds to: ZIMO MX617L

8-pole sound decoder (NEM 652)

10890



Sound decoder with wires and 8-pole plug; can be updated; multiprotocol operation possible; motor control; braking tracks supported; comfortable change of operating parameters possible: i.e. the locomotive does not have to be opened; overcurrent protection; RailCom*

Technical data:

- ▶ DCC + RailCom*, DC analogue, MM, AC analogue
- ▶ Dimensions: 30 x 15 x 4 mm
- ▶ 1.2 A motor, total (peak 2.5 A)
- ▶ 10 function outputs
- ▶ 2 outputs for additional functions
- ▶ Servo control cables or SUSI
- ▶ Function low voltage 5 V (200 mA)
- ▶ External energy storage (16 V) directly connectable
- ▶ 3 Watt audio, 4–8 Ohm, 32 Mbit, 6 channels

Corresponds to: ZIMO MX645R

PluX22 sound decoder (NEM 658)

10891



Sound decoder with 22-pole plug; can be updated; multiprotocol operation possible; motor control; braking tracks supported; comfortable change of operating parameters possible: i.e. the locomotive does not have to be opened; overcurrent protection; RailCom*

Technical data:

- ▶ DCC + RailCom*, DC analogue, MM, AC analogue
- ▶ Dimensions: 30 x 15 x 4 mm
- ▶ 1.2 A motor, total (peak 2.5 A)
- ▶ 9 function outputs
- ▶ 2 outputs for additional functions
- ▶ Servo control cables or SUSI
- ▶ Function low voltage 5 V (200 mA)
- ▶ External energy storage (16 V) directly connectable
- ▶ 3 Watt audio, 4–8 Ohm, 32 Mbit, 6 channels

Corresponds to: ZIMO MX645P22

8 pole sound decoder (NEM 652)

10892



Sound decoder with wires and 8-pole plug; can be updated; multiprotocol operation possible; motor control; braking tracks supported; comfortable change of operating parameters possible: i.e. the locomotive does not have to be opened; overcurrent protection; RailCom*

Technical data:

- ▶ DCC + RailCom*, DC analogue, MM, AC analogue
- ▶ Dimensions: 20 x 11 x 4 mm
- ▶ 0.8 A motor, total (peak 1.5 A)
- ▶ 6 function outputs
- ▶ 2 logic level outputs for additional functions
- ▶ Servo control cables or SUSI
- ▶ 1 Watt audio, 8 Ohm, 32 Mbit, 6 channels

Corresponds to: ZIMO MX648R

PluX16 sound decoder (NEM 658)

10893



Sound decoder with standard sounds and 16-pole plug; can be updated; multiprotocol operation possible; motor control; braking tracks supported; comfortable change of operating parameters possible: i.e. the locomotive does not have to be opened; overcurrent protection; RailCom*

Technical data:

- ▶ DCC + RailCom*, DC analogue, MM, AC analogue
- ▶ Dimensions: 20 x 11 x 4 mm
- ▶ 0.8 A motor, total (peak 1.5 A)
- ▶ 4 function outputs
- ▶ 2 logic level outputs for additional functions
- ▶ Servo control cables or SUSI
- ▶ 1 Watt audio, 8 Ohm, 32 Mbit, 6 channels

Corresponds to: ZIMO MX648P16

8 pole decoder (NEM 652)

10894

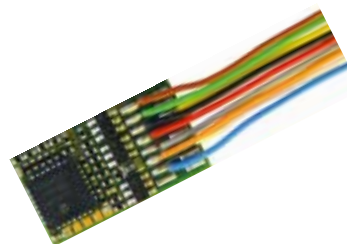

Decoder with wires and 8-pole plug; can be updated; multiprotocol operation possible; motor control; braking tracks supported; comfortable change of operating parameters possible: i.e. the locomotive does not have to be opened; overcurrent protection; RailCom*

Technical data:

- ▶ DCC + RailCom*, DC analogue, MM, AC analogue
- ▶ Dimensions: 20 x 11 x 3.5 mm
- ▶ 1.0 A motor, total (peak 2.5 A)
- ▶ 6 function outputs
- ▶ 2 logic level outputs for additional functions
- ▶ Servo control cables or SUSI

Corresponds to: ZIMO MX630R

PluX16 decoder (NEM 658)

10895

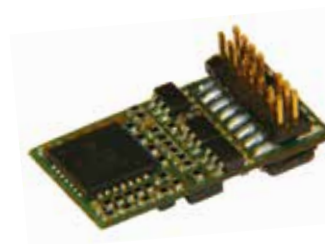

Decoder with 16-pole plug; can be updated; multiprotocol operation possible; motor control; braking tracks supported; comfortable change of operating parameters possible: i.e. the locomotive does not have to be opened; overcurrent protection; RailCom*

Technical data:

- ▶ DCC + RailCom*, DC analogue, MM, AC analogue
- ▶ Dimensions: 20 x 11 x 3.5 mm
- ▶ 1.0 A motor, total (peak 2.5 A)
- ▶ 6 function outputs
- ▶ 2 logic level outputs for additional functions
- ▶ Servo control cables or SUSI

Corresponds to: ZIMO MX630P16

PluX22 decoder (NEM 658)

10896



Decoder with 22-pole plug; can be updated; multiprotocol operation possible; motor control; braking tracks supported; comfortable change of operating parameters possible: i.e. the locomotive does not have to be opened; overcurrent protection; RailCom*

Technical data:

- ▶ DCC + RailCom*, DC analogue, MM, AC analogue
- ▶ Dimensions: 22 x 15 x 3.5 mm
- ▶ 1.2 A motor, total (peak 2.5 A)
- ▶ 9 function outputs
- ▶ 2 logic level outputs for additional functions
- ▶ Servo control cables or SUSI

Corresponds to: ZIMO MX633P22



ACCESSORIES

Train controller and switching power supply

10798



This controller set is best suited for beginners and running just one train. It consists of one controller and plug-in transformer, designed to compliment each other. The controller gives a definite forwards and backwards control and speed settings. The control knob clicks gently into a zero position. Automatic overload protection. Easy connection to the layout using the pressure connection clips.

Technical data:

Running voltage: 0–14 V= / 0.6 A
Separate accessory output: 14 V= / 0.85 A

Switching power supply

10723



For accessory feed.
Attention: Not suitable for z21/Z21!
15 V ~, 400 mA

DC power jack

10749



This adapter enables the Z21 switch DECODER (10836) or the Z21 signal DECODER (10837) to be easily supplied with a switching power supply such as the 10851 or the 10850.

Light transformer for high capacity

670601



This transformer is the high capacity power pack for the operation of electromagnetic items such as signals, turnout drives, relays, illumination and other accessories

- ▶ It has an integrated thermal protection switch against short circuit and overload
- ▶ Easy connection to the layout using the pressure connection clips
- ▶ Distribution with 10726

2 outputs:

Cable: 16 V~ / 2.5 A (for 10764 and 10765); Clips: 14 V~ / 2.85 A

The transformer replaces the former article 6706 (FLEISCHMANN) and 10725 (ROCO).

Power distributor

10726



Necessary for connecting var. accessories (turnouts, light, signals, etc.) to the new transformers/switching power supplies. Input is a coaxial socket, outputs – via a luster terminal and four 3-pole connector zones (to our existing connection system 10603) and via a fixed cable with a coaxial connector to the control device or the digital device.

Connectors and cables

10602

Cable plugs



Adapters for connecting three single cables with flat connector system (10603).

10603

3-pole connector



10605

5-pole connector



10608

8-pole connector



10616

16-pole connector



Single-pole cable. Different colours. Conductor cross section 0.2 mm². Length 10 m

10630



10631



10632



10633



10634



10635



10636



10637



10638



3-pole flat ribbon cable

Conductor cross section 0.2 mm², length 10 m.

10623



5-pole flat ribbon cable

Conductor cross section 0.2 mm², length 10 m.

10625



8-pole flat ribbon cable

Conductor cross section 0.2 mm², length 10 m.

10628



Change over button

10520

Change over button with feedback function. For four magnetic items switched off at the end (turnouts, semaphore signal, relays, etc.).

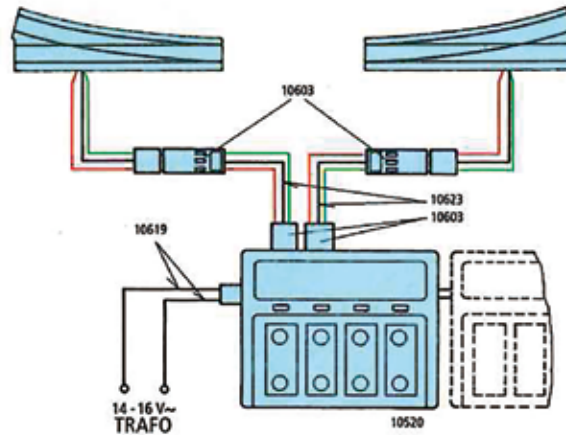

Change over button

10521

Change over button without feedback function. For four solenoid-operated articles (turnouts, signals, relays) without automatic end-position switch-off.

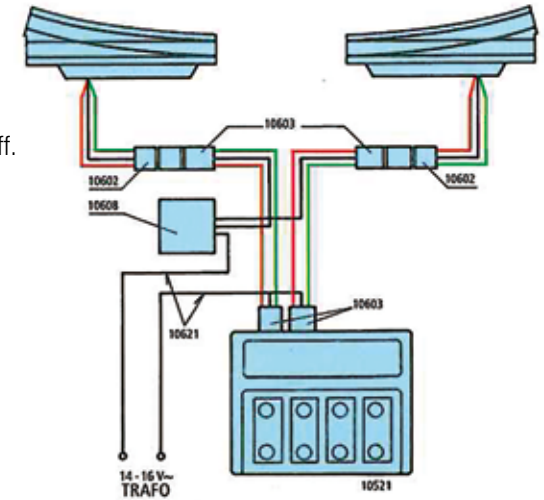

Change over switch

10524

The switch is used wherever alternating switch-on connections are necessary (Lighting, Separate track sections). It is connected via the connector zone. Each individual switch is designed for maximum permissible current of 0.5 A.

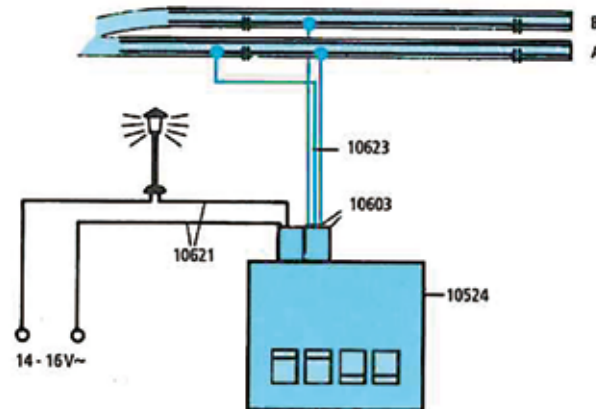

Light signal switch

10525

Signal switch with feedback and train control. With one switch, two two-aspect light signals (e. g. 40020), can be operated without magnetic drive.

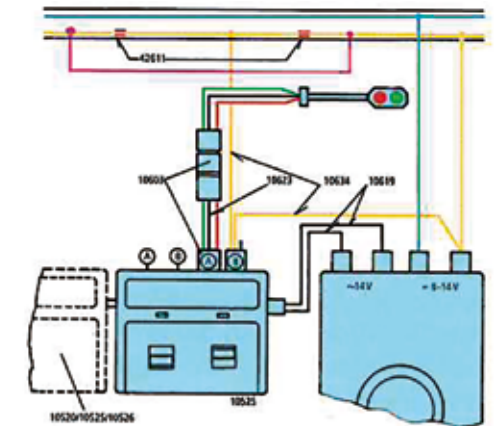

Single action button for uncoupling tracks

10522

Use this unit wherever power must be supplied for a short time. The individual buttons are electrically insulated and thus they can operate different power circuits.

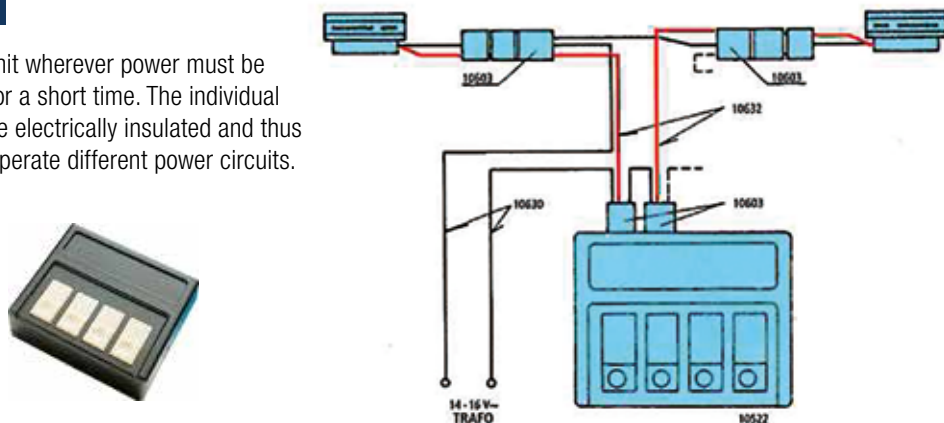

Change over button

10526

Change over button with feedback. For single-slip turnouts and symmetric three-way turnouts.

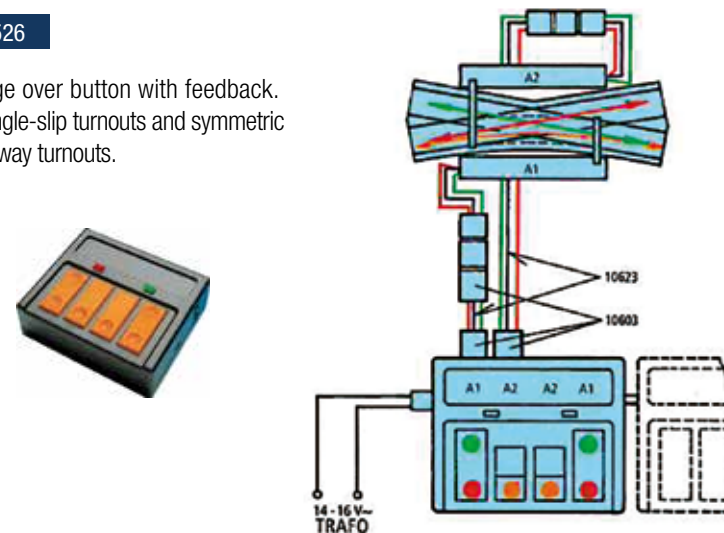

Universal relay

10019

With four change-over contacts. Current load per contact: max. 1.5 A

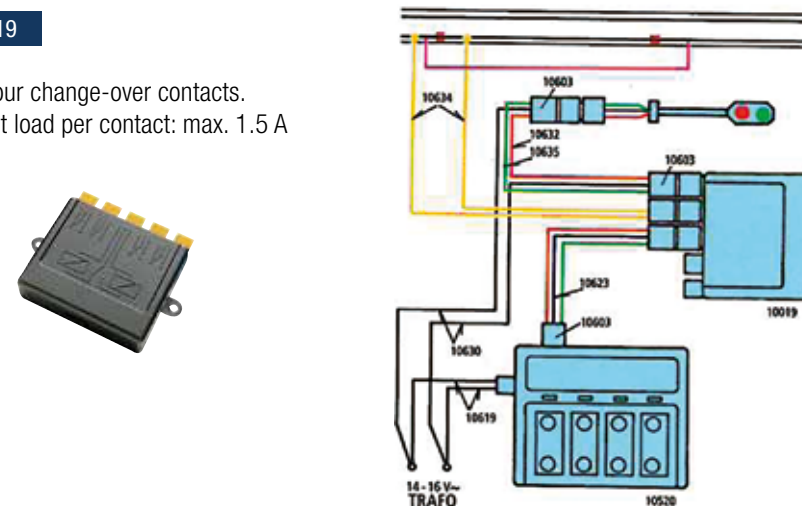

Connecting cable

10619

For switches 10520, 10525, 10526, length 1.20 m.



Lightings

40420

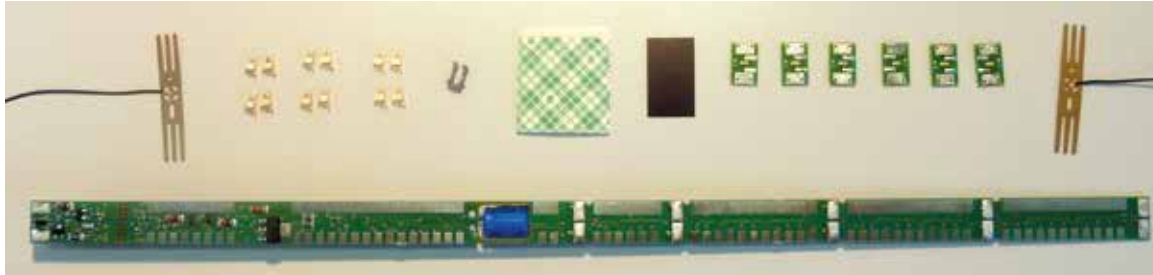

LED universal lighting set for 4 axle H0 wagons with a length from 170 up to 316 mm

The six LED modules with a warm white LED each can be optionally positioned on the carrier board so that an adaption to the interior is possible. The carrier board can be shortened however the power supply is still possible on both sides. It can be used in analogue as well as digital operation with AC or DC. With 16 pin PluX interface. The LED modules can be switched in groups in digital operation.

40360



Universal lighting kit for 4-axled H0 wagons

Contains a 300 mm flexible strip conductor, 5 bulb carriers, 5 bulbs 16 V/22 mA, 2 wheel current pick-up contacts, fastening material.

40361

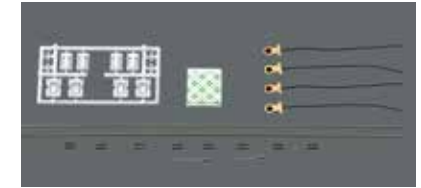

Universal lighting kit for 2-3-axled H0 wagons

Contains a 150 mm flexible strip conductor, 2 bulb carriers, 2 bulbs 16 V/22 mA, 4 wheel current pick-up contacts, fastening material.

40321

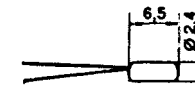

Light bulb with leads 16 V/22 mA 5 pc/pack

40322

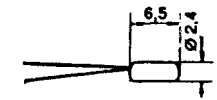

Light bulb with leads 12 V/60 mA 5 pc/pack

93517

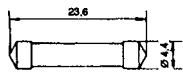

Tubular bulb 16 V, 30 mA

93518

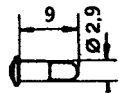

Bulb, plug-in-socket 2.8, 12 V, 50 mA

109088

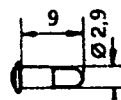

Bulb, plug-in-socket 2.8, 16 V, 30 mA

93728

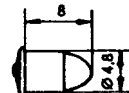

Bulb, plug-in-socket 4.8, short version, 16 V, 50 mA

93733

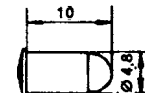

Bulb, plug-in-socket 4.8, long version, 16 V, 50 mA

101366

Lighting unit for the unpowered head of the class VT 11.5/601 diesel multiple unit

40314



Interior lighting retrofit set and headlights

Interior lighting retrofit set and headlights (bulb) with direction of travel dependent light change for IR/IC driving coaches 44935/44936/44937, (1:100).

In addition: Replacement bulbs 12 volt: 93518 and 93734.
Replacement bulbs 16 volt: 109088 and 93517.

40317



Interior lighting retrofit set and headlights

Interior lighting retrofit set and headlights (bulb) with direction of travel dependent light change for coaches 44942/44959, (1:100).

In addition: Replacement bulbs 12 volt: 93521 and 93734.
Replacement bulbs 16 volt: 93728 and 93517.

Couplings

40395



Universal coupling for NEM 362 standard coupler pocket.
12 pc/pack

40397



Universal coupling for NEM 362 standard coupler pocket.
50 pc/pack

40396



Height adjustable universal coupling.
Spacing extended by approx. 2 mm per coupler. 12 pc/pack

40343



Close coupling mechanism retrofit set for 2-axle wagons up to 140 mm in length. Drawbar with standard coupler pocket (NEM 362). Without close coupling heads. 12 pc/pack

40344



Close coupling mechanism retrofit set for 2-axle cars over 140 mm and for bogie cars up to 170 mm in length. Without close coupling heads. 12 pc/pack

40270

4 pc/pack.

40271

50 pc/pack.



Close coupler head with advanced uncoupler for NEM 362

40281

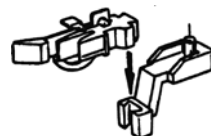

Close coupler head with advanced uncoupler. Suitable for FLEISCHMANN vehicles with trunnion pocket. 2 pc/pack

40286

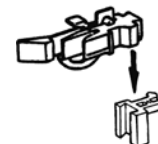

Close coupling heads with advanced uncoupler
Suitable for Ade-cars, height adjustable. 2 pc/pack

40287

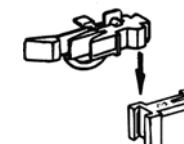

Close coupling heads with advanced uncoupler, height adjustable. 2 pc/pack

40411



Digital coupler kit with feedback feature

Consists of 1 multi protocol special decoder for AC and DC operation and 2 couplings. The couplings can be controlled only by this decoder. If decoders of other manufacturers are used, the couplings can be damaged. For 8-pin interfaces according to NEM 652. Automatic driving current recognition Motorola*/DCC or analogue DC/AC. Automatic driving recognition 14/28/128 settings.

40345



Electric coupling, 4-pole

This coupling is used for extending the supply and control voltages from locomotive to wagon, or from wagon to wagon. 2 pc./pack

40326



Close coupling retrofit kit

With coupling draw-bar. 2 pc./pack



40243



Standard D-link coupling
for NEM 362 standard coupler socket. 2 pc./pack

40244



FLEISCHMANN hook couplings
for standard coupling pockets NEM 362, 2 pc./pack

40375



Claw coupling for Swedish LKAB ore wagons, 2 pc./pack

40376



Central buffer coupling "AK69e" for NEM shaft with dovetail fitting. Standard coupler pocket. 2 pc./pack

40390



H0e stirrup coupling
2 pc./pack

6516



FLEISCHMANN PROFI slot coupling
1 pc./pack

386516



FLEISCHMANN PROFI slot coupling (bulk pack) 50 pc./pack



Wheel sets

40177

DC NEM standard wheel set
2 pc./pack, Ø 10
Axle length: 24.8 mm

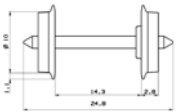

40178

AC wheel set
2 pc./pack, Ø 10,
Axle length: 24.8 mm

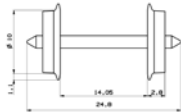

40179

AC wheel set
2 pc./pack, Ø 10,
Axle length: 23.8 mm

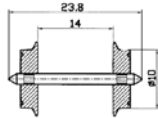

40180

DC NEM standard wheel set
2 pc./pack, Ø 10 mm,
Axle length: 23.8 mm.
One side insulated.

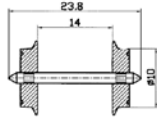

40181

AC fine-cast metal spoke wheel set
2 pc./pack, Ø 11 mm,
Axle length: 24.75 mm

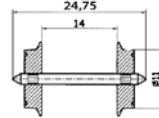

40182

DC NEM standard wheel set
2 pc./pack, Ø 11 mm,
Axle length: 23.8 mm

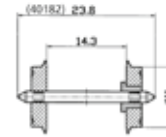

40183

AC wheel set
2 pc./pack, Ø 11 mm,
Axle length: 23.8 mm

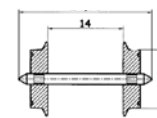

40184

AC wheel set
2 pc./pack, Ø 7.5 mm,
Axle length: 24.75 mm

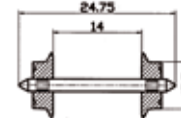

40186

Wheel set with 18 kΩ resistor
2 pc./pack, Ø 11 mm,
Axle length: 24.75 mm

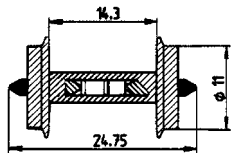

40187

Wheel set with 18 kΩ resistor
2 pc./pack, Ø 9 mm,
Axle length: 24.75 mm

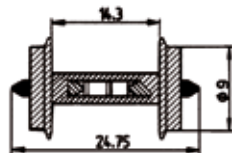

40188

DC NEM standard spoked wheel set
2 pc./pack, Ø 11 mm,
Axle length: 24.75 mm. One side insulated.



40189

DC NEM standard wheel set
2 pc./pack, Ø 7.5 mm, Axle length:
24.75 mm. Insulated on both sides.

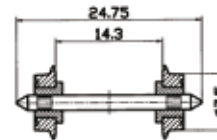

40190

DC NEM standard fine-cast spoked wheel set. With split axle.
2 pc./pack, Ø 11 mm,
Axle length: 24.75 mm



6560

AC wheel set
Axle length: 24 mm. Ø 11 mm. Not insulated.
To convert all 2- and 3-axled FLEISCHMANN wagons fitted with disc wheels, as well as all 4-axled wagons with a length of 282 mm for use on 3-rail, centre pick up AC voltage tracks.



6561

AC wheel set
Axle length: 25 mm. Ø 11 mm. Not insulated.
To convert all 4-axled wagons with disc wheels (except wagons which should be fitted with 6560) for use on 3-rail, centre pick up AC voltage tracks.



6562

Spoked wheel set for AC operation
Axle length: 23.5 mm. Ø 11 mm. Not insulated.
To convert FLEISCHMANN coaches with spoked wheels for use on 3-rail, centre pick up AC voltage tracks.



6563

Double spoked wheel set for AC operation
Axle length: 24 mm. Ø 11 mm. Not insulated.
To convert all FLEISCHMANN goods wagons fitted with spoked wheels for use on 3-rail, centre pick up AC voltage tracks.



40191

DC NEM standard wheel set

With split axle, Ø 9 mm,
2 pc./pack

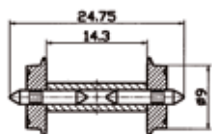

40192

DC NEM standard wheel set

With split axle, Ø 11 mm,
2 pc./pack

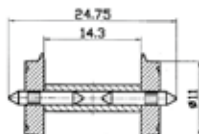

40193

DC-NEM standard wheel set

With split axle. For passenger
coaches type N28.
Ø 11 mm, 2 pc./pack

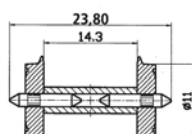

40194

DC NEM standard wheel set

DC insulated on one side,
Ø 9 mm, 2 pc./pack

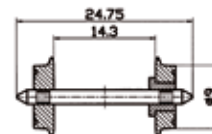

40195

AC wheel set

Ø 9 mm, 2 pc./pack

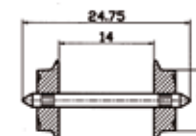

40196

AC wheel set

Ø 11 mm, 2 pc./pack

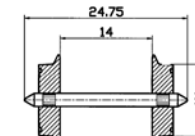

40197

DC NEM standard wheel set

Insulated on both sides,
Ø 9 mm, 2 pc./pack

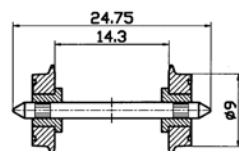

40198

DC NEM standard wheel set

Insulated on one side,
Ø 11 mm, 2 pc./pack

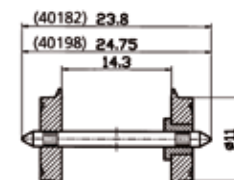

40199

DC NEM standard wheel set

Insulated on both sides,
Ø 11 mm, 2 pc./pack

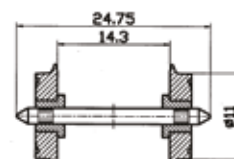

40264

RP-25 wheel set

DC insulated on one side,
Ø 11 mm, 2 pc./pack

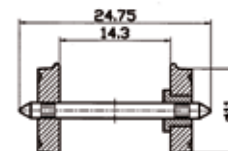

40266

RP-25 wheel set

DC insulated on one side,
Ø 9 mm, 2 pc./pack

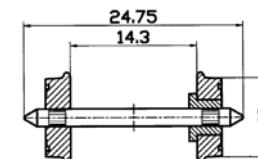

40267

RP-25 wheel set

DC with split axle, Ø 11 mm,
2 pc./pack

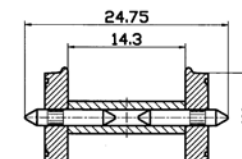

DC traction tyre sets

40066 For wheels, 12.5–13.8 mm diameter.
10 pc./pack

40067 Ø 6.8–8.2 mm. 10 pc./pack

40068 Ø 8.3–10.2 mm. 10 pc./pack

40069 Ø 10.3–12.8 mm. 10 pc./pack

40070 Ø 12.9–14.6 mm. 10 pc./pack

40071 Ø 14.7–16.5 mm. 10 pc./pack

40072 Ø 16.5–19.0 mm. 10 pc./pack



AC traction tyre sets

40073 For wheels, 8.8–10.2 mm diameter.
10 pc./pack

40074 Ø 10.3–12.4 mm. 10 pc./pack

40075 Ø 12.5–15.3 mm. 10 pc./pack

40076 Ø 15.4–17.5 mm. 10 pc./pack

40077 Ø 17.5–20.0 mm. 10 pc./pack



Smoke generator

40160



Smoke generator for class 80, class 36, class 03.10 and "Württemberg C"/class 18.1 for analogue and digital operation.

SEUTHE steam-smoke-distillate

10908



Content:
50 ml steam-smoke-distillate
1 syringe

Preparation set for locos

40014



Accessories for upgrading model locomotives.

Figure set: Engine driver and fireman

40001



Painted, 3 pc. each/pack

H0 Railway figures (unpainted)

40000



For do-it-yourself painting
24 pc./pack

AC PICK-UP SHOES

40500



Short version,
length 42 mm

40501



Long version,
length 56 mm.

82111



Long version, slim,
length 56 mm.

Brake shoes

40004

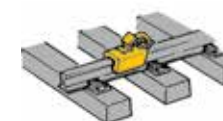

For clipping onto the rail,
12 pc./pack

Chocks for H0 trucks

40005

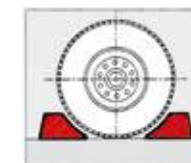

12 pc./pack

Hobbyist's saw

10900



All purpose hobbyist's saw. For cutting track sections to size.

Lubricating grease

10905



Particularly suited for plastic gears and provides an excellent glide effect. Contents: 8 g

Oiler

10906



Practical tool for properly "lubricating" sintered bearings of model locomotives. One drop per lubricating point is sufficient!

Excavator shovel for gantry crane

46807



Fully functional model that can be used with the mobile cranes 40110 and 40111.

Microfibre cloth

10003



12 pc./pack

3 piece set: 20' tank container

05216



To be used in the combined traffic.

3 piece set: 20' container

05217



To be used in the combined traffic.

Box girder bridge

40080



Length: 22.86 cm
Width: 7.5 cm

The bridges can be clipped together within in minutes without using adhesives.

Arched bridge

40081



Length: 45.7 cm
Width: 7.5 cm

Bridge pillars

40082

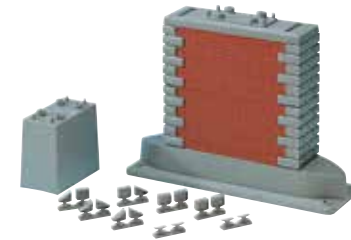

Height: 9.4 cm.
Suitable for bridges 40080 and 40081.

Display cases

40025



For models with maximum length of 22 cm.
Size (L x W x H): 23.8 x 7.5 x 7.5 cm
(without model)

40026



Display case for items with a maximum length of 29 cm.
Size (L x W x H): 35 x 6 x 8 cm



TRACKS

The ROCO LINE track is a high quality sleeper track. It is equally suitable for model railway beginners as well as for professionals. With a few simple steps and without any special technical knowledge, you can build a coherent model railway layout that's true to the original. The sleeper track made of nickel silver is highly resistant to corrosion and shows barely any scuffs after years of use. Due to its specific rail profile and surface sealing, dirt can hardly settle on the rails. There is a consistent contact between the rail and the wheels and thus an uninterrupted power supply of the vehicles is guaranteed. In addition, the conventional slightly curved railhead ensures an acoustically and mechanically smooth running of the vehicles on the layout.

The profile height of 2.1 mm gives the ROCO LINE track its original look. With seven parallel circuits, eight different turnout designs as well as flexible tracks the ROCO LINE offers you almost all options to build a model railway layout true to the original. Through the transitional rail joiners (42612), the ROCO LINE track layout can be easily connected to all kinds of systems with 2.5 mm rail profile.

Orientation

The ROCO LINE track system uses both article numbers and "descriptive" short designations for different elements of its geometry. These short designations, e. g. G1 for standard straight track will be shown on all track plan illustrations, instructions, packaging and on the track units themselves.

Straight tracks

In principle you can build the ROCO LINE track layout with only two straight tracks of different lengths. All other straight tracks (except the diagonal track) are parts or multiples of the standard track. It's that simple!

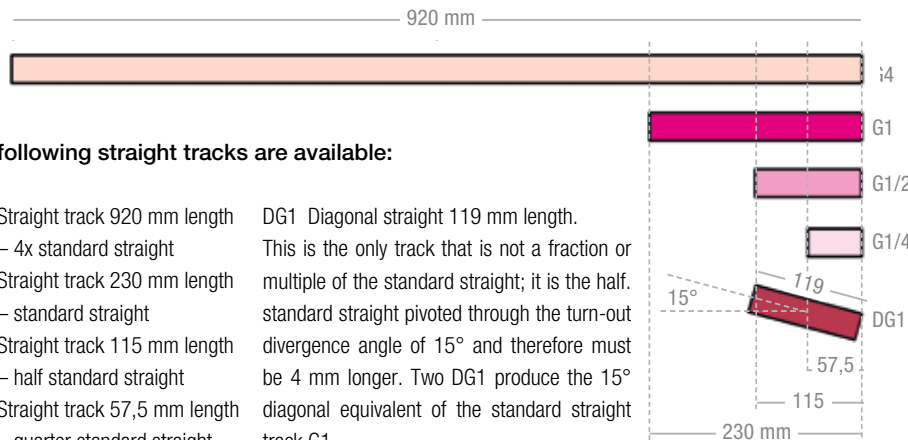

The following straight tracks are available:

- | | | | |
|------|--|-----|---|
| G4 | Straight track 920 mm length
– 4x standard straight | DG1 | Diagonal straight 119 mm length.
This is the only track that is not a fraction or multiple of the standard straight; it is the half standard straight pivoted through the turn-out divergence angle of 15° and therefore must be 4 mm longer. Two DG1 produce the 15° diagonal equivalent of the standard straight track G1. |
| G1 | Straight track 230 mm length
– standard straight | | |
| G1/2 | Straight track 115 mm length
– half standard straight | | |
| G1/4 | Straight track 57,5 mm length
– quarter standard straight | | |

Curved Tracks

A full circle (360°) requires 12 units of curved tracks. The track separation of 61.6 mm assures that trains with correct scale length express coaches may pass without touching even on adjacent R2/R3 radius track.

ROCO LINE offers 5 basic radii with a parallel track separation of 61.6 mm:

- R2** curve 30°, r= 358 mm
- R3** curve 30°, r= 419.6 mm
- R4** curve 30°, r= 481.2 mm
- R5** curve 30°, r= 542.8 mm
- R6** curve 30°, r= 604.4 mm

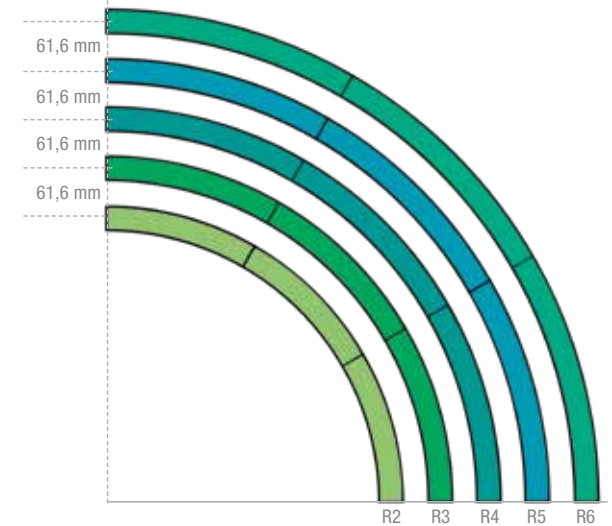

Large radii for turnouts and transition curves:

- R9** curve 15°, r= 826,4 mm
- R10** curve 15°, r= 888 mm – revers curve for the 15° turnout
- R20** curve 5°, r= 1962 mm – revers curve for the 10° turnout

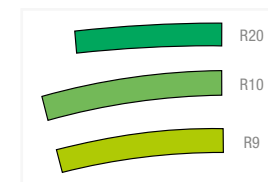

These curved units may be assembled into a complete 360° circle as well. For R9 and R10 a total of 24, for R20 a total of 72 sections is required. These generous radii are often used as transitional radii in combination with the standard radii R2-R6. So you could start e.g. with three curves R20 and connect them to one curve R10 and continue your layout with 30° curves R2-R6.

Examples for combining individual elements

With the help of some examples we will show, how to combine individual elements of the ROCO LINE track system. Only a few important illustrations can be shown here.

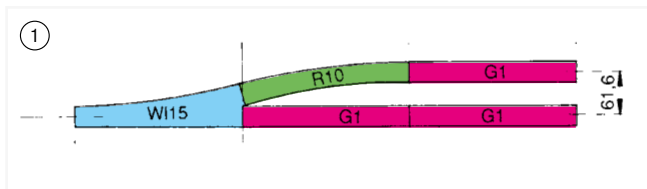

Illustration 1

A simple branch with reverse curve, assembled with a standard straight track G1, one WI15 and one R10. Both tracks will end exactly at the grid line and have the correct separation of 61.6 mm.

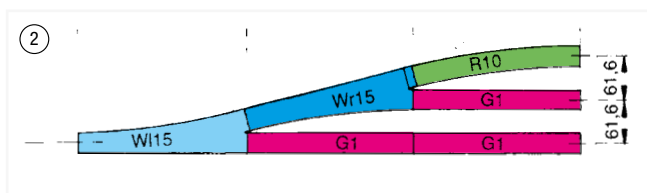

Illustration 2

A third track is added to the track sidings. The straight trough track of the turnout is usually, in prototype as well as in the model, placed in the diagonal direction. This track formation appears to be quite simple but leads to compromises in many conventional track systems. The ROCO LINE track system maintains the correct parallel of 61.6 mm and all three tracks end exactly at the grid line. This is made possible by an 8 mm length extension unit (D8), which is supplied with each 15° turnout.

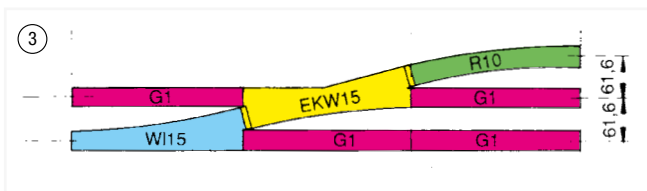

Illustration 3

A single or double slip turnout can be used instead of a standard turnout. Here too the shortened diagonal requires a geometrically correct length compensation. Two 4 mm units (D4) solve this problem without additional trouble for the modeler.

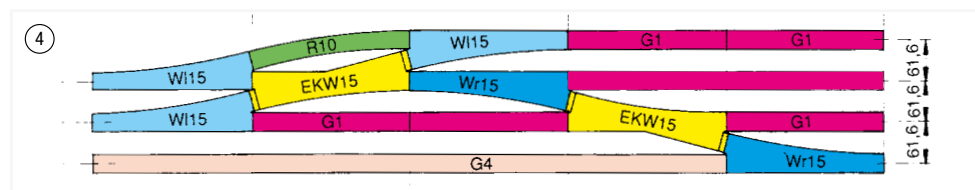

Illustration 4

Crossings may be arranged either left or right hand. To save the modeler the problem of correct choice at time of purchase and to avoid limiting their utilisation by having different crossing designs, all ROCO LINE crossings are supplied with the previously mentioned 4 mm units. As shown in this example, the identical crossing may be used alternatively as right- or left hand crossing. The example also shows how a single slip may be bypassed, as is done by the prototype, by using two turnouts and one R10. The advantage of this track formation compared to a double slip turnout is the possibility of parallel entry or simultaneous entry and exit of trains into and from a station.

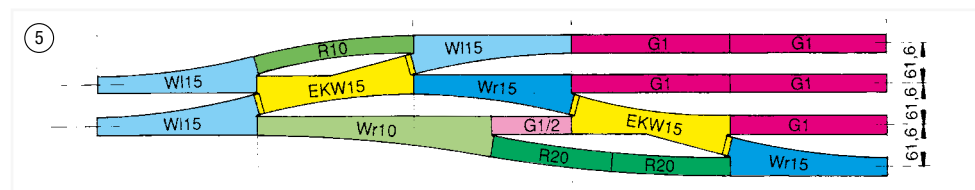

Illustration 5

This shows how the slim 10° turnouts may be easily incorporated into a track formation which contains only 15° turnouts and crossings. Please note that the reverse curve to the 10° turnouts is formed by two track sections R20.

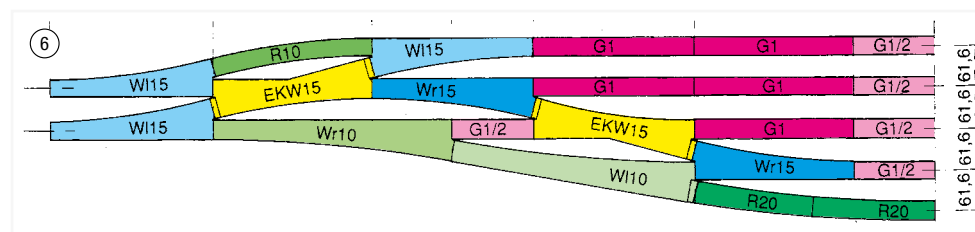

Illustration 6

Instead of the reverse curve to the 10° turnout it is of course possible to insert another 10° turnout, with the straight trough track of the turnout placed at the diagonal. For this arrangement the 10° turnouts are supplied with a 5 mm unit (D5) which assures the correct length to the next grid line. Here again the track separation and the track ending at the grid spacing are maintained.

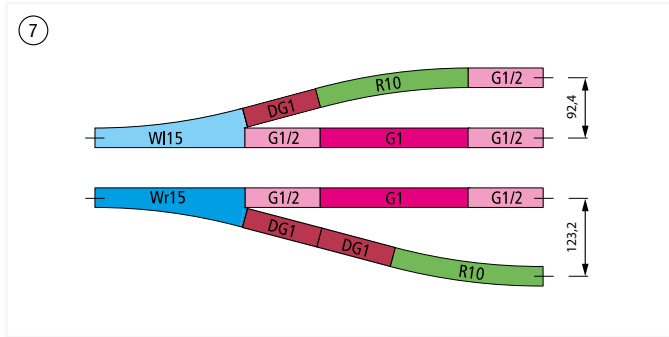

Illustration 7

Using the diagonal straight DG1, the parallel track spacing can be extended in 30.8 mm steps. Therefore, inserting a DG1 results in a parallel track spacing of 92.4 mm. This distance is ideal for Faller or Vollmer platforms. The wider Kibri platforms will also fit if the measurements are taken carefully. When using two DG1s, the double parallel track spacing of 123.2 mm can be achieved. Here you can build your own wide platforms or use the wider platforms from Auhagen.

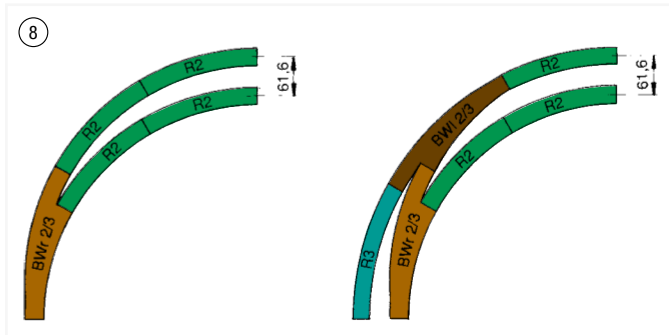

Illustration 8

With the left- or right hand curved turnouts it is possible to form the track branches and connections shown above, whereby the completion of the 90° circle sector is easily achieved with standard R2 or R3 track units.

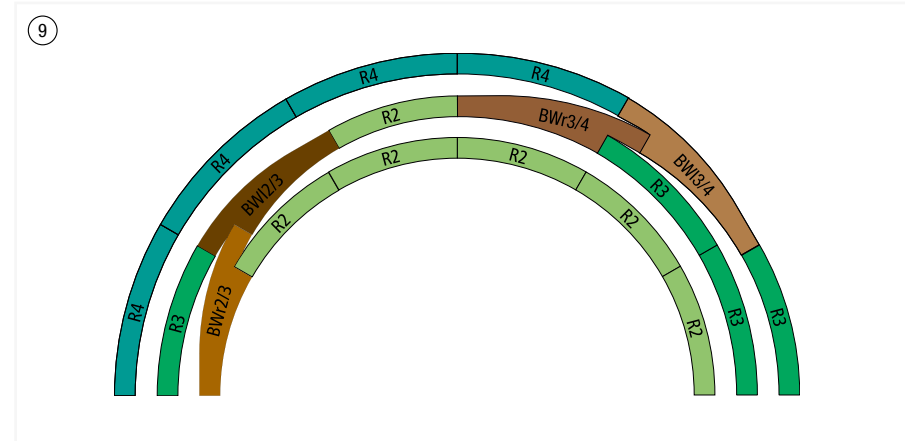

Illustration 9

With the left and right turnouts R2/3 and R3/4, the track connections as shown in the illustration, can be built via three parallel turnouts from radius 2 to radius 4 within a semicircle. To complete the 180° circle sector you can use the standard track pieces R2, R3 and R4.

Turnouts

The ROCO LINE turnouts with their slender crossing frogs guarantee a flawless and visually appealing model railway operation that is true to the original. All turnouts are supplied without turnout mechanisms. Optionally, manual (40297/40298) or electric above ground turnout mechanisms (40295/40296) can be mounted. For underground operation the switch turnout mechanism 10030 can be used.

Polarization

Polarization is necessary for good running properties, in particular for small locomotives. The polarization of the turnout frogs is mostly prepared. If you use the electric turnout drives 40295/40296, a connection can be made with a few easy steps. For this purpose only three short electrical connections between the connecting sockets that are located at the front of the drive and under the side-mounted sleeper rust of the turnout must be made. For this no soldering is required. If an underground drive 10030 is used, one of the four switches can be used for the polarization.

Spacers

Turnouts or crossings occasionally come with attached diagonal spacers (D4, D8, D12). These are necessary in order to extend the straight line according to grid dimensions during the installation of diagonal turnouts. At crossings, they enable you to continue your layout either left or right. No additional compensation pieces thus are required for the construction of a railway station complex.

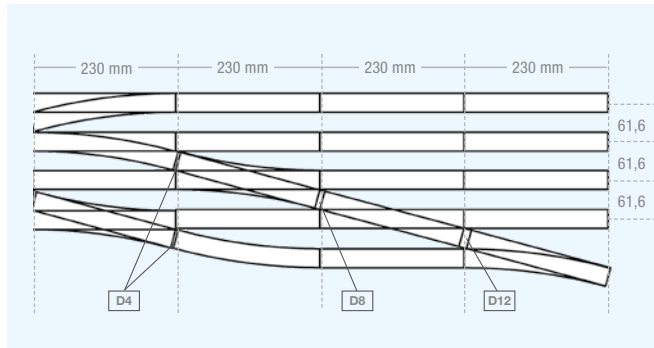

The spacers are also available individually as spare parts:

With bedding:

- item: 98004 (D2)
- item: 98005 (D4)
- item: 98006 (D5)
- item: 98007 (D8)
- item: 98009 (D12)

Without bedding:

- item: 98000 (D2)
- item: 98001 (D4)
- item: 98002 (D5)
- item: 98003 (D8)
- item: 98008 (D12)

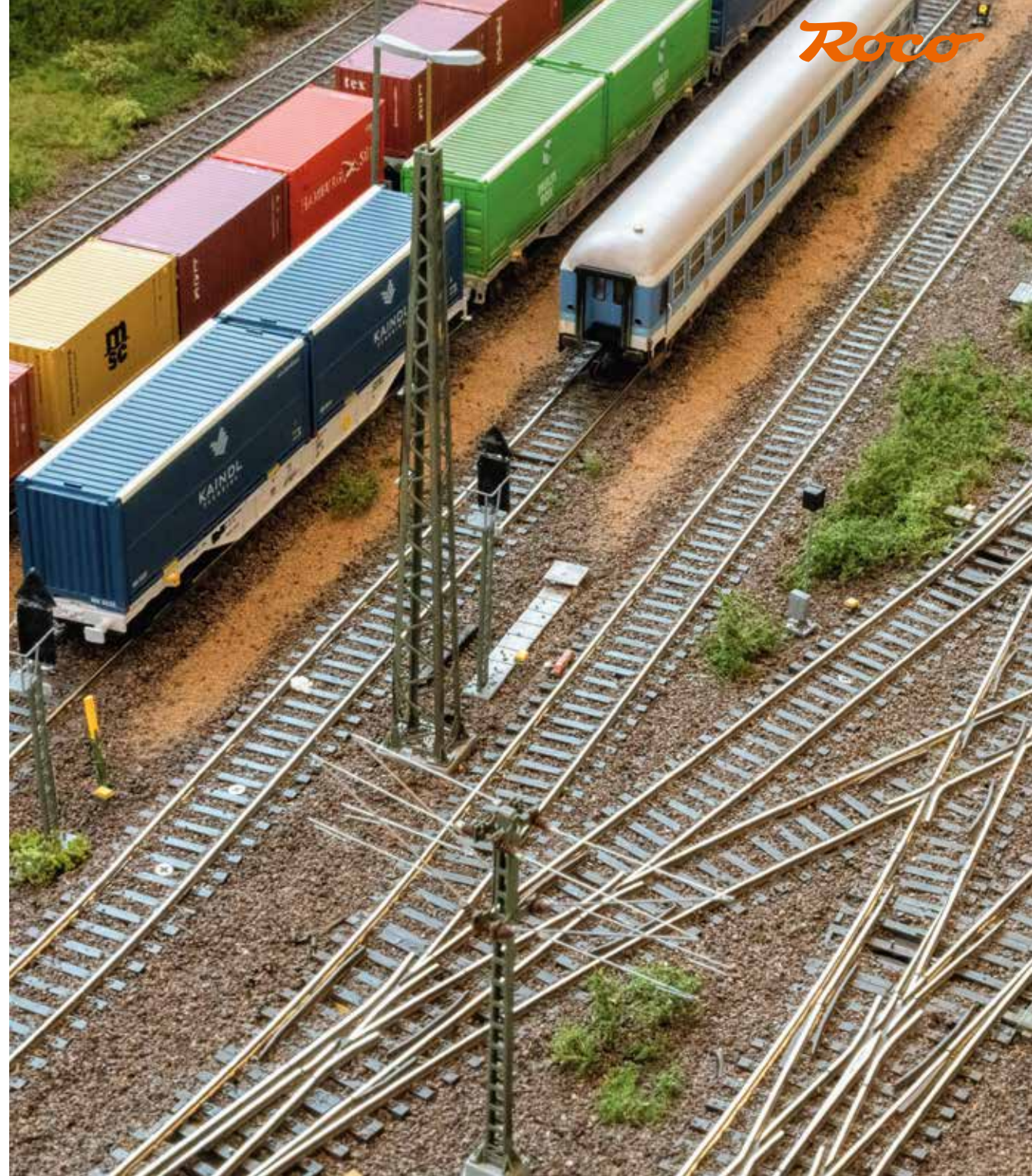

On the to-scale ROCO LINE track system with a 2.1 mm rail profile, the track bed is already included. This allows you to create any individual system design you want, whatever the surface under the tracks. In addition, on a stationary system, you can save yourself the time-consuming and troublesome gravelling of tracks.

The intelligent yet well-structured ROCO LINE track system with 10° and 15° turnout elements and eight different radii leaves sufficient leeway for variable and striking track shapes. The solid nickel-silver alloy profile of the track system combined with the robust plastic subconstruction is a guarantee for the sturdiness and impact resistance of the track section elements. It is thus able to withstand a few misplaced steps taken in the thrill of the game. Clip elements integrated into the plastic grid provide additional track unit safety and also permit a sturdy "suspended construction". The electric turnout drive 42620 or the digital turnout drive 42624 can be inconspicuously accommodated in the bed at the turnouts.

The rubber-like bed permits the quietest-possible driving operation: Your train will simply glide over the whisper-quiet ROCO LINE tracks. Only the even "tack-tack" of the wheelsets on the rail joints remain audible, ensuring a really lifelike railway sound. The excellent conductivity of the nickel-silver profiles as well as the polarisable cores on the turnouts also ensure a soft and jerk-free ride for the trains in your own small model railway world.

Straight tracks

42506

Straight track G4

Length 920 mm (4x standard length).



42510

Straight track G1

Length 230 mm (standard length).

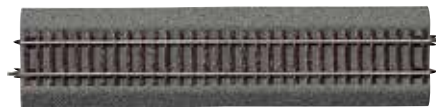

42512

Straight track G½

Length 115 mm (half standard length).



42513

Straight track G¼

Length 57.5 mm (quarter standard length).



42511

Straight track DG1

diagonal straight element. Length 119 mm.

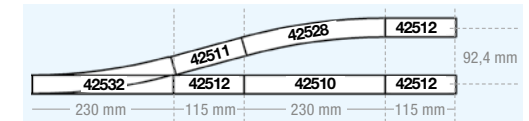

Circuit track

42518

Circuit track

with potential-free switching contact.

Length 115 mm (G½).



Decoupler track

42519

Electric uncoupler track

Length 115 mm (G½),

The electromagnetic drive is completely hidden inside the bedding.



Feeder tracks

42521

Feeder track (G½)

with EMC interference suppressor. Not suitable for digital operation!

Length 115 mm.

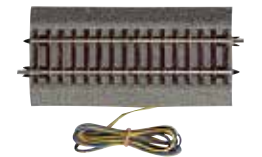

42517

Digital feeder track (G½)

This feeder track is not equipped with interference suppressors for radio interference suppression and therefore only approved for use in digital systems.



Curved tracks

42522

Curved track R2
Radius 358 mm, 30°.



42523

Curved track R3
Radius 419.6 mm, 30°.



42524

Curved track R4
Radius 481.2 mm, 30°.



42525

Curved track R5
Radius 542.8 mm, 30°.



42526

Curved track R6
Radius 604.4 mm, 30°.



42527

Curved track R9
Radius 826.4 mm, 15°.



12 pieces of radii R2–R6 are needed for each full circle.

42508

Curved track R2 ¼
Radius 358 mm, 7,5°.

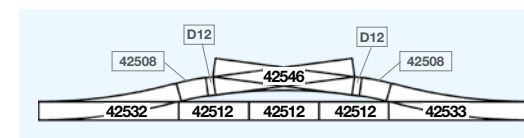

42509

Curved track R3 ¼
Radius 419.6 mm, 7,5°.



42528

Curved track R10
Radius 888 mm, 15°.
(Opposite curve for 15° turnouts and crossings).

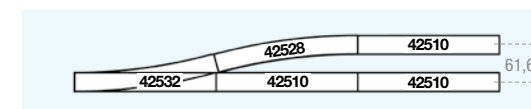

42530

Curved track R20
Radius 1.962 mm, 5°.
2 piece constitute complementary curve for 10° turnouts and crossings.

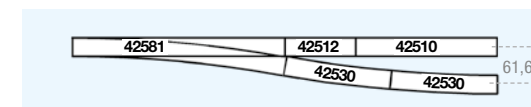

Turnouts 15° / Crossings

42532

Turnout left hand Wl15, manually operated

Length 230 mm (standard length), branch angle 15°, branch radius 873.5 mm, frog angle 10.8°, with pre-installed polarization.
An 8-mm spacer element (D8) is included for diagonal installation.
Suitable motor: 42620 or 42624.



42533

Turnout right hand Wr15, manually operated

Built as 42532.



42546

Single slip turnout EKW15, manually operated

Length 230 mm, standard design with internal switch rails.
Branch radius 531 mm, crossing angle 15°.
For diagonal installation two D4 and one D12 are included.



Suitable motor: (2x) 42620 or (2x) 42624.

42594

Double slip turnout DKW15, manually operated

Design "Baeseler" with switch rails located at the outside.
Length 230 mm, crossing angle 15°, effective branch radius 1,050 mm.
For diagonal installation two D4 and one D 12 are included.
Owing to the geometrical characteristics of this type of double slip turnout it is necessary to always use it polarized.



Suitable motor: (2x) 42620 or (2x) 42624.

42543

Three-way turnout DWW15, manually operated

First divergence to the left, second divergence to the right. Length 287.5 mm (= G1 + G¼), branch angle 15° each, branch radius 873.5 mm each, frog angle 10.8°. To adapt the length a 57.5 mm G¼ straight track element and spacers D12 and D4 are included.



Suitable motor: (2x) 42620 or (2x) 42624.

Crossings

42597

Crossing K15

Length 230 mm, crossing angle 15°. By using a 10019 relay it is possible to polarize the frogs and incorporate the crossing like a normal solenoid accessory in a route locking. The railroad lines that cross each other are not electrically isolated.

Two D4 and one D12 are included for diagonal installation.



42598

Centrepiece for double crossover DGV15

Length 115 mm, crossing angle 30°. Suitable in combination with 15° turnouts/slip turnouts. The railroad lines that cross each other are not electrically isolated.

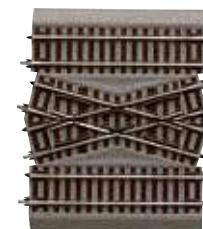

Turnouts 10° / Crossings

42580

Turnout left Wl10, manually operated

Length 345 mm (= G1 + G½), branch angle 10°, branch radius 1946 mm, frog angle 8.1°.

A 5-mm spacer element (D5) is included for diagonal installation.

Suitable motor: 42620 or 42624.



42581

Turnout right Wr10, manually operated

Built as 42580.

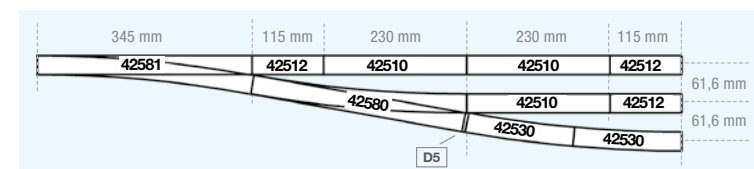

42591

Single slip turnout EKW10, manually operated

Length 345 mm, branch radius 959 mm, crossing angle 10°. Standard design with internal switch rails.

Two distancers D2 and one D8 are enclosed for length compensation.



Suitable motor: 42620 (2x) or 42624 (2x).

42549

Double slip turnout DKW10, manually operated

Length 345 mm, branch radius 959 mm, crossing angle 10°. Standard design with internal switch rails.

Two distancers D2 and one D8 are enclosed for length compensation.

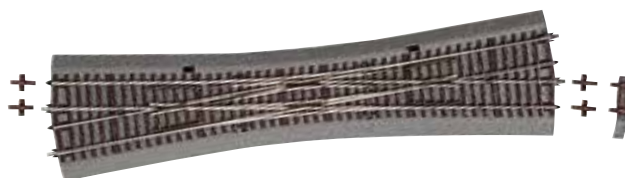

Suitable motor: 42620 (2x) or 42624 (2x).

More illustrations and examples see page 49.

Curved turnouts

R2/R3



42556

Curved turnout left BWI2/3, manually operated

Radius of main track and branch track 358 mm (R2), arc angle 30°, with polarization.
Suitable motor: 42620 or 42624.

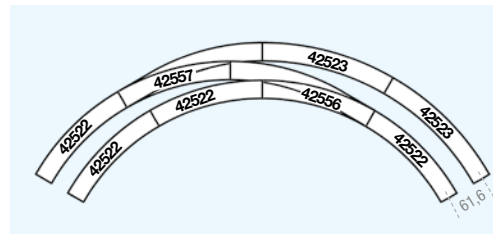

42557

Curved turnout right BWr2/3, manually operated

Radius of main track and branch track 358 mm (R2), arc angle 30°, with polarization.
Suitable motor: 42620 or 42624.

R2/R3: The use of the curved turnout R2/R3 for long ,to-scale' express train coaches (length over buffers more than 300 mm) is inconvenient.

R3/R4



42572

Curved turnout left BWI3/4, manually operated

Radius of main track and branch track 419.6 mm (R3), arc angle 30°. Suitable motor: 42620 or 42624.

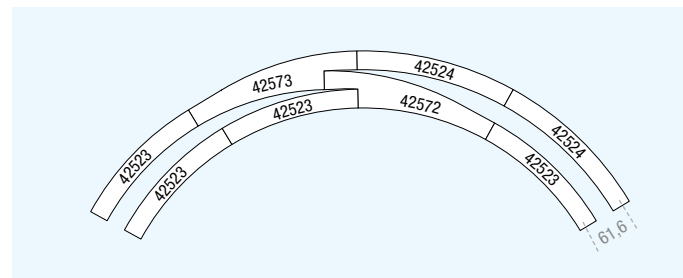

42573

Curved turnout right BWr3/4, manually operated

Radius of main track and branch track 419.6 mm (R3), arc angle 30°. Suitable motor: 42620 or 42624.

- ▶ Newly designed frog pieces ensure a smooth crossing
- ▶ Turnout opening/width in the frog piece area according to NEM standards

R5/R6



42570

Curved turnout left BWI5/6, manually operated

Radius of main track and branch track 542.8 mm (R5), arc angle 30°.

Suitable motor: 42620 or 42624.

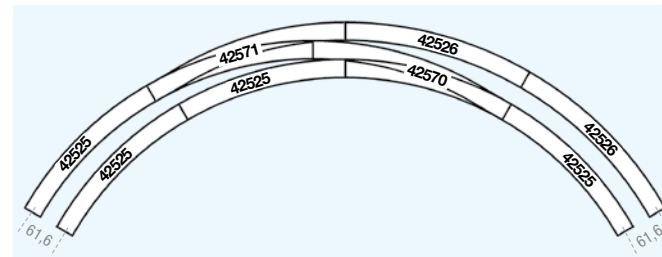

42571

Curved turnout right BWr5/6, manually operated

Radius of main track and branch track 542.8 mm (R5), arc angle 30°.

Suitable motor: 42620 or 42624.

R9/R10



42568

Curved turnout left BWI9/10, manually operated

Radius of main track and branch track 826.4 mm (R9), arc angle 30°.

Suitable motor: 42620 or 42624.

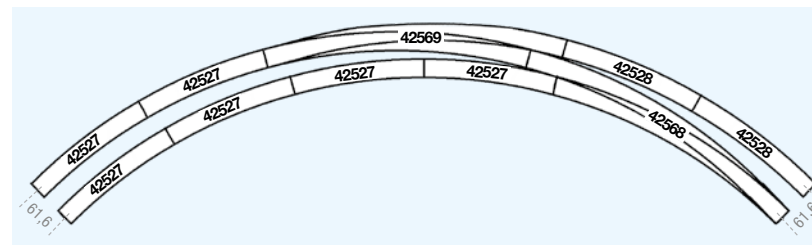

42569

Curved turnout right BWr9/10, manually operated

Radius of main track and branch track 826.4 mm (R9), arc angle 30°.

Suitable motor: 42620 or 42624.

Track sets - The ABC of ROCO LINE tracks

A proven idea – complete track sets for youngsters as well as grown-up model railway enthusiasts – becomes even more attractive with the ROCO LINE track system with bedding: excellent appearance as well as rugged and reliable for setting up and operating. During the succession of track formations A–E the beginners learns the clear geometric design. The track set are also an economical means for the experienced modeler to become acquainted with the ROCO LINE track system by obtaining a universally applicable basic stock of the major track elements.

The individual sets contain the coloured tracks shown in the illustrations. The sets contain manually operated turnouts which may be fitted with electromagnetic bedding turnout drive 42620 or with the electric turnout drive 42624 (with DCC decoder).

The individual sections just have to be clipped together as shown in the illustrations and a train can start running. The ROCO LINE tracks are held together without additional fasteners and can be assembled directly on the floor.

Track set A

42010 Track set B

42011 Track set C

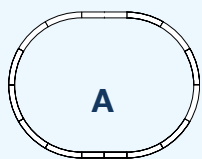

Space requirement ca. 120 x 100 cm

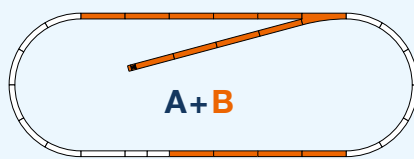

Space requirement starting with set B ca. 240 x 100 cm

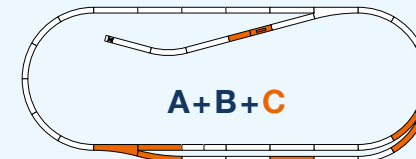

The track set A is the minimum layout contained in all starter sets and cannot be purchased separately. All other tracks sets are extensions of this layout.

Track set A consists of:

- 12 curved tracks R2 (42522)
- 1 straight track G1 (42510)
- 1 straight track G 1/2 (42512)
- 1 feeder track (G 1/2) (42521)

Running round and round becomes boring. Adding a single turnout and siding makes the layout more interesting. Set A + B is actually the minimum track layout to start a model railway. Therefore Set B is also part of some starter sets.

Track set B consists of:

- 13 straight tracks G1 (42510)
- 1 manual turnout left W15 (42538)
- 1 buffer stop kit (42608)
- 1 roadbed end piece (42651)

A long passing siding and a hand-operated uncoupler are part of set C and bring additional diversification into the operation.

Track set C consists of:

- 2 straight tracks G1 (42510)
- 1 curved track R10 (42528)
- 2 curved tracks R2 (42522)
- 1 straight track G1/2 (42512)
- 1 manual uncoupler track G1/2
- 1 manual curved turnout right BWr2/3 (42559)
- 1 manual turnout right Wr15 (42539)

42012 Track set D

42013 Track set E

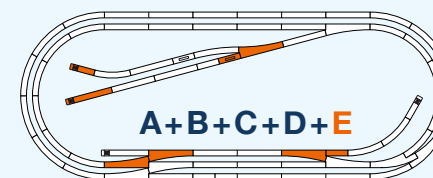
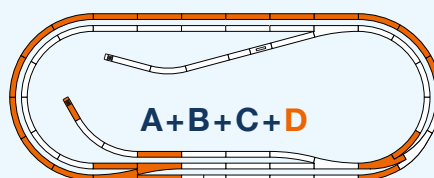

If the layout assembled from set A through C should have double track, set D should be used. The layout will then have a third station track. Track changes in both directions make the operation even more interesting.

Track set D consists of:

- 9 straight tracks G1 (42510)
- 1 straight track G1/2 (42512)
- 1 curved track R2 (42522)
- 10 curved tracks R3 (42523)
- 2 manual tournouts left W15 (42538)
- 1 manual curved turnout left BW12/3 (42558)
- 1 buffer stop kit (42608)
- 1 track end piece (42651)
- 1 substitute embankment slopes (42650)

Track set E expands the operating possibilities in a realistic manner by additional track connections and more sidings. Track set E consists of:

- 2 straight tracks G1/2 (42512)
- 1 straight track G1 (42510)
- 2 manual tournouts left W15 (42538)
- 2 manual tournouts right Wr15 (42539)
- 1 manual uncoupler track G1/2
- 2 buffer stop kits (42608)
- 2 track end pieces (42651)

Flexible tracks

Even though the ROCO LINE track system offers a large choice of straight and curved track sections, prototype-oriented track planning and assembly require individually fitted track curvatures, whether for "exhibition" track sections, stations built into wide curves with 5 meter or larger radius, or combination of turnouts with tricky connections. The solution in these situations is "flex track".



No track system for model railway application can be complete without flexible tracks. They do not conform to any specific geometry other than the length of the flexible track being exactly 4x the standard length; they may be bent as tightly as radius R2 (358 mm). For tram lines even up to 220 mm.

42400

Flex track F4 with wooden sleepers

Length 920 mm.



42401

Flex track F4 with concrete sleepers

Length 920 mm.



Use of flex track:

Flex track may be bent to any curve as tightly as radius $R2 = 358$ mm. Since the rails will move relative to each other while bending, it is necessary to cut one rail to match.

The ROCO hobby saw 10900 (see page 31) is recommended for this purpose. When using flex track, track fixing pins, fishplates and sleeper end pieces must be used.

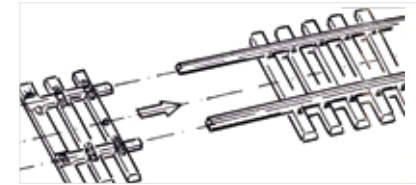

42600



Sleeper end piece. To match flex track with wooden sleepers (42400). 12 units/pack.

42601



Sleeper end piece. To match flex track with concrete sleepers. 12 units/pack.

Each flex track requires a track and end piece on only **one** side.

Track bed

42660

Track bed

suitable for 1 flex track with wooden sleepers (42400).

42661

Track bed

suitable for 1 flex track with concrete sleepers (42401).



The prototypical and flexible ROCO LINE track system is also available without a bedding. The high-quality sleeper band track is suitable for model railway beginners and professionals alike. You can construct a prototypical model railway system in only a few easy steps and without requiring prior specialist knowledge. The ROCO LINE track system made from nickel-silver is exceptionally corrosion-resistant and suffers hardly any wear, even after years of use. It is also highly resistant to dirt due to the rail profile and the special surface seal. In this way, good contact is guaranteed between the rails and the wheels as well as an uninterrupted supply of electricity for your vehicles for the maximum possible period. In addition, the prototypical, slightly concave rail head ensures the quiet and mechanically smooth running of your locomotives and wagons.

Featuring eight radii, and meanwhile 17 different turnout constructions as well as flexible tracks, ROCO LINE offers almost all the possibilities for realising a prototypical system. Using the transitional rail connectors, the ROCO LINE track system can also easily be connected to systems with 2.5 mm rail profiles. Instead of the turnout side drives 40295/40296, it is also possible to use the underfloor drive 10030 which is intended for fixed-construction systems and is mounted under the board. With its 4 switch contact groups, it is not only a practical solution for many switching tasks, but can also be mechanically connected to the atmospherically-illuminated turnouts lantern set 40293.

The ROCO LINE track system with its generously-dimensioned branch radii, various 15° turnouts, slimline 10° turnouts and the elegant curved turnouts is sufficiently variable even for the most unusual track shapes: This is a track system for individualists, who may also enjoy gravelling the sets of turnouts right up to the turntable.

Straight tracks

42406

Straight track G4

Length 920 mm (4x standard length).



42410

Straight track G1

Length 230 mm (standard length).



42412

Straight track G½

Length 115 mm (half standard length).



42413

Straight track G¼

Length 57.5 mm (quarter standard length).



42411

Straight track DG1

Length 119 mm. Diagonal straight element.

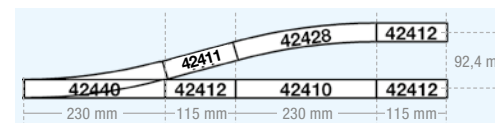

DG1: The diagonal straight track makes the extension of the distance between the parallel tracks possible but the rail siding still remains on the grid line.

Uncoupler track

42419

Electric uncoupler track (G½)

Length 115 mm.

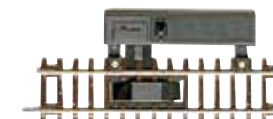

Feeder track

42421

Feeder track (G½)

with EMC interference suppression unit. Not suitable for digital operation! Length 115 mm.

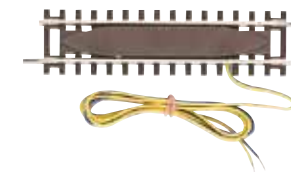

Curved tracks

42422

Curved track R2
Radius 358 mm, 30°.



42423

Curved track R3
Radius 419.6 mm, 30°.



42424

Curved track R4
Radius 481.2 mm, 30°.



42425

Curved track R5
Radius 542.8 mm, 30°.



42426

Curved track R6
Radius 604.4 mm, 30°.



42427

Curved track R9
Radius 826.4 mm, 15°.



12 pieces of radii R2–R6 are needed for each full circle.

42408

Curved track R2 ¼
Radius 358 mm, 7.5°.



R2 ¼

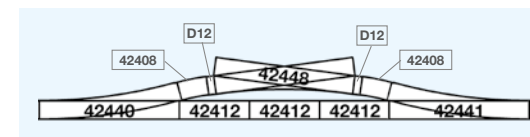

42409

Curved track R3 ¼
Radius 419.6 mm, 7.5°.



R3 ¼

42428

Curved track R10
Radius 888 mm, 15° - Opposite curve for 15° turnouts and crossings.



R10

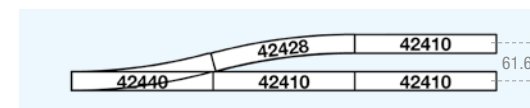

42430

Curved track R20
Radius 1962 mm, 5°.
Two piece constitute complementary curve for 10° turnouts and crossings.



R20

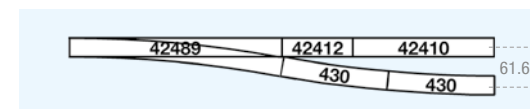

Turnouts 15° / Crossings

42440

Turnout left W15

Length 230 mm (= standard length G1), branch angle 15°, branch radius 873.5 mm. An 8-mm spacer element (D8) is included for diagonal installation.

Suitable motor:
40295, 40297, 10030.

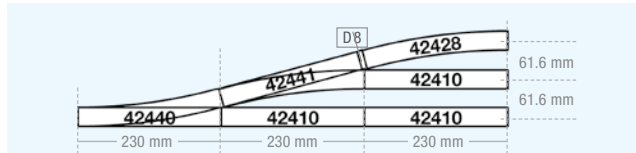

42441

Turnout right Wr15

Built as 42440.

42448

Single slip turnout EKW15, Standard design with internal switch rails.

Length 230 mm, branch angle 15°, branch radius 531 mm. For diagonal installation two D4 and one D12 are included.

Suitable motor:
2x 40295/40297 or 2x 10030.



42497

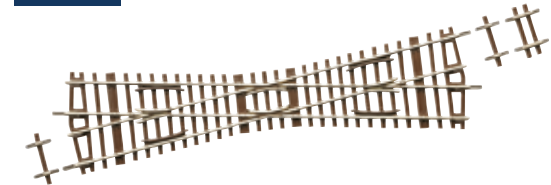

Crossing K15, Length 230 mm, branch angle 15°.

By using a 10019 relay it is possible to polarize the frogs and incorporate the crossing like a normal solenoid accessory in a route locking. The railroad lines that cross each other are not electrically isolated. Two D4 and one D12 are included for diagonal installation.

15°
Crossing

42451

Double slip turnout DKW15, Design "Baeseler" with closure blades located at the outside. Length 230 mm. Branch angle 15°, effective branch radius 1050 mm.

For diagonal installation two D4 and one D 12 are included.

Suitable motor:
2x 40295/40296, 2x 40297/40298 or 2x 10030.

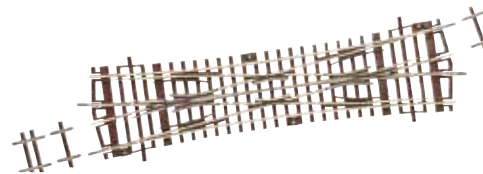

Owing to the geometrical characteristics of this type of double slip turnout it is necessary to always use it polarized.

42454

Three-way turnout DWW15, Length 287.5 mm (= G1 + G¼), branch angle 15° each, branch radius 873.5 mm. To adapt the length a 57.5 mm G¼ straight track element and spacers D12 and D4 are included.

Suitable motor:
2x 40296 or 2x 10030.

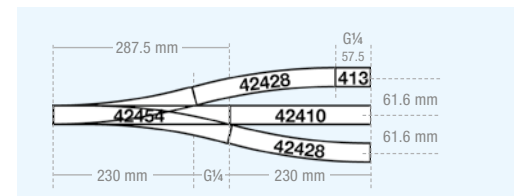

Turnouts 10° / Crossings

42488

Turnout left W110

Length 345 mm (G1 + G½), branch angle 10°, branch radius 1946 mm. A 5-mm spacer element (D5) is included for diagonal installation.

Suitable motor:

40295, 40297, 10030.



42489

Turnout right Wr10

Suitable motor:

40296, 40298, 10030.

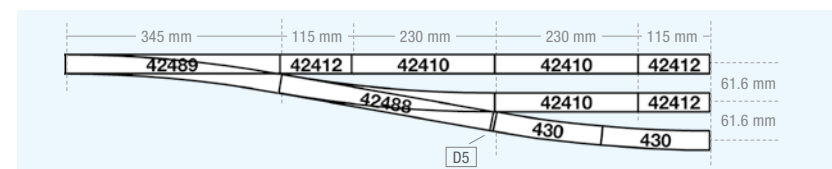

42493

Single slip turnout EKW10. Length 345 mm, crossing angle 10°, branch radius 959 mm.

For installation crossing from left or right two 2.5 mm spacers (D2) are included. An 8 mm spacer element (D8) is included for combining with diagonally installed 10° turnouts.

Suitable motor:

2x 40295/40297 or 2x 10030.

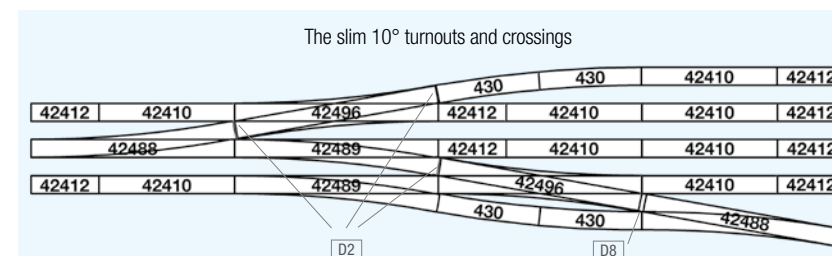

42496

Double slip turnout DKW10, standard design with internal switch rails, Length 345 mm. Crossing angle 10°, branch radius 959 mm. For installation crossing from left or right two 2.5 mm spacers (D2) are included. An 8 mm spacer element (D8) is included for combining with diagonally installed 10° turnouts.

Suitable motor:

2x 40295, 2x 40297 or 2x 10030.

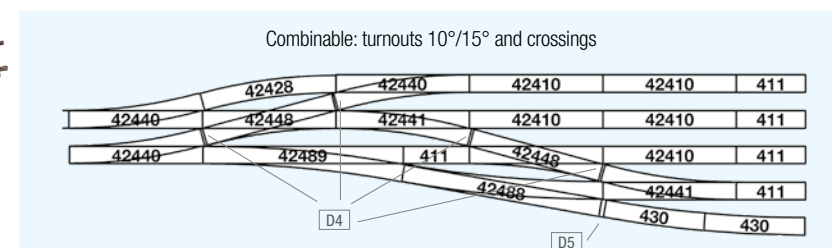

42498

Crossing K30, Length of tracks 119 mm (= DG1). Crossing angle 30°.

The railroad lines that cross each other are not electrically isolated. Among other things they are suitable for forming double track connections with the 15° turnouts or slip turnouts.



30°
Crossing

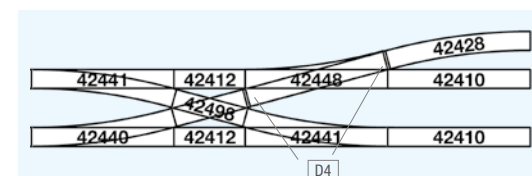

Curved turnouts

R2/R3: The use of the curved turnout R2/R3 for long ,to-scale' express train coaches (length over buffers more than 300 mm) is inconvenient.

R2/R3

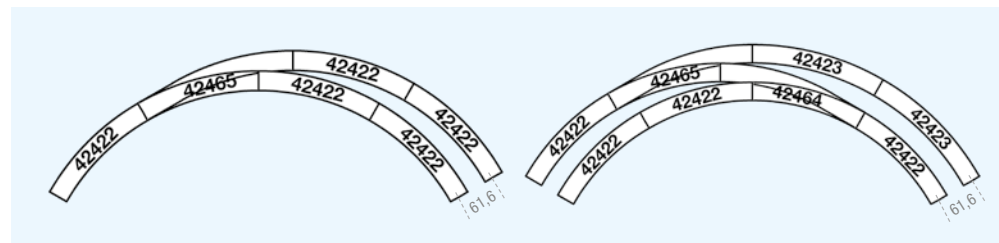

42464

Curved turnout left BWI2/3

Radius of main track and branch track 358 mm (R2), arc angle 30°. Suitable motor: 40295/40296, 40297/40298 or 10030.

42465

Curved turnout right BWr2/3

Radius of main track and branch track 358 mm (R2), arc angle 30°. Suitable motor: 40296/40295, 40297/40298 or 10030.

R3/R4

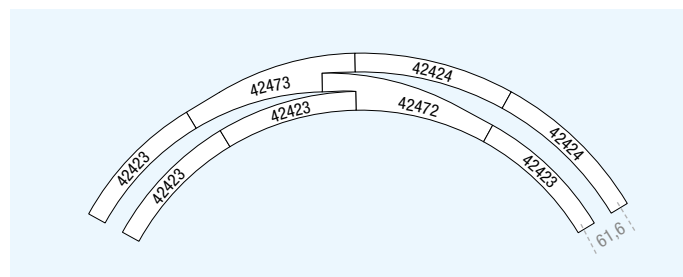

42472

Curved turnout left BWI3/4

Radius of main track and branch track 419.6 mm (R3), arc angle 30°. Suitable motor: 40295/40296, 40297/40298 or 10030.

42473

Curved turnout right BWr3/4

Radius of main track and branch track 419.6 mm (R3), arc angle 30°. Suitable motor: 40295/40296, 40297/40298 or 10030.

- ▶ Newly designed frog pieces ensure a smooth crossing
- ▶ Turnout opening/width in the frog piece area according to NEM standards

R5/R6

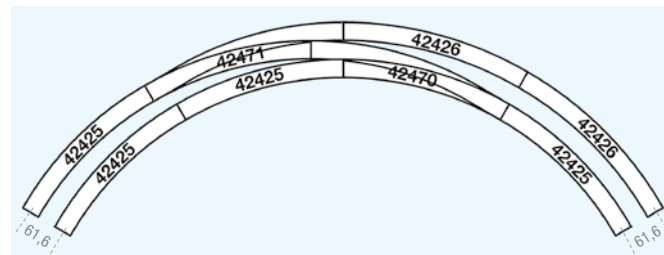

42470

Curved turnout left BWI5/6

Radius of main track and branch track 542.8 mm (R5), arc angle 30°. Suitable motor: 40295/40296, 40297/40298 or 10030.

42471

Curved turnout right BWr5/6

Radius of main track and branch track 542.8 mm (R5), arc angle 30°. Suitable motor: 40295/40296, 40297/40298 or 10030.

R9/R10

42476

Curved turnout left BWI9/10

Radius of main track and branch track 826.4 mm (R9), arc angle 30°. Suitable motor: 40295/40296, 40297/40298 or 10030.

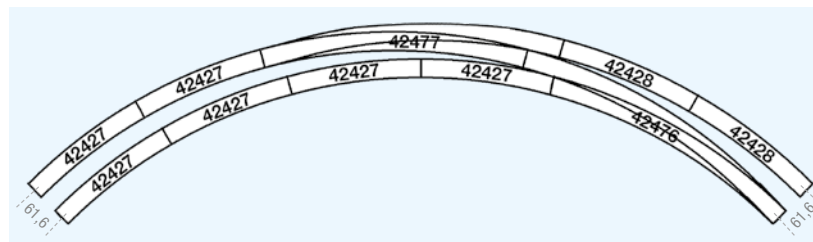

42477

Curved turnout right BWr9/10

Radius of main track and branch track 826.4 mm (R9), arc angle 30°. Suitable motor: 40295/40296, 40297/40298 or 10030.



ROCO LINE turntable with electric below-baseboard propulsion mechanism and control unit

42615

Suitable for all NEM (European model railway standard) compatible two-rail DC and three-rail AC model railways. Bridge length: 253 mm; this is equivalent to 22 m on an original railway. The minimum angle between two track connections is 9 degrees. Spacers for 1°, 3°, 6° and 9° divisions are supplied with the turntable. This means that any division from 9° upwards in 1° stages between the track connections is feasible. The maximum number of track connections that can be made is 40.

Four track connections for two-rail DC operation are supplied with the turntable. Further track connections are available as accessories (42616). If the turntable is to be used with a three-rail AC model railway, your specialist dealer will exchange the enclosed original DC pack to a pack of three-rail AC track connections (42617).

The turntable bridge drive is powered by 14 V AC. Depending on the system used, traction power supply will either be DC or AC. The turntable is equipped with a control unit for preselecting the direction of rotation and starting the turntable rotation. When you let go of the turntable switch, the turntable halts exactly at the next track connection. We only recommend the AC plug-in transformer (10723) for power supply of the turntable movement via the manual control unit!

Just like on a real-life turntable, it is also possible to choose between two rotation directions. Traction power is fed in via the turntable. The traction voltage of the track connections can be assigned via the control unit. This prevents a locomotive that is currently parked from inadvertently moving off if two track connections are located directly opposite to one another.*

One 1-meter 5-pole cable (connection between transformer and control unit) and one 2-meter 8-pole cable (connection between control unit with the turntable) are enclosed.



Installation dimensions:

Required installation opening: 280 mm.

Installation depth measured from table top edge: 50 mm.

External diameter of the turntable without track connections: 307 mm.

Turntable bridge length: 253 mm.

Suitable for all locomotives up to a total wheel base of 250 mm.

42616

DC track connections

Content: 4 units 2L = track connections, for turntable 42615.



42617

AC track connections

Content: 3 units 3L ~ track connections, for turntable 42615.



* The terminal loop module is required when using the turntable in DCC mode (digital).



Universal bedding turnout drive

42620

Universal bedding turnout drive

Low switching current consumption, limit switch.



Note please: Like all ROCO turnout drives, this drive of course features a limit turnout. However, as the adjuster of the drive is held in its end position by the tongue adjustment mechanism of the turnout itself (and only then will the limit switch function reliably), please do not try out the turnout drive unless it is clip-connected to a turnout.

42624

Digital turnout drive

Suitable for all ROCO LINE bedding turnouts.



The digital turnout drive is simply plugged into the recess on the underside of the turnouts. The electrical connection is made with two cables directly to the rail profiles. The digital turnout drive already includes a DCC decoder (this new version is Rail-Com* compatible) and can be programmed after installation.

Track ballast

42652



Matches roadbed track in terms of colour and grain. Genuine stone ballast.

Substitute embankment slopes

42650



Length 360 mm each.
6 pc./pack

Ballast board

42653



Ballast board to fill in the spaces between the tracks in the train station area. Colour and grain size match the bedding track. Size: 345 x 93 mm.
3 pc./pack

Embankment end piece

42651



These end pieces provide a neat closure of the bedding at buffer stops, display cases etc.
6 pc./pack

Flexible toothed racks for ROCO LINE tracks

42602



Length: each 230 mm.
Flexible installation in straight and curved tracks.
Can be used from radius 2 (r= 358 mm).

Assembly aid for ROCO LINE toothed rack

42603



For easy positioning of the fastening on the tracks.
Nailing aid.



40295



Electric turnout mechanism left
for Roco LINE turnouts without bedding.

40296



Electric turnout mechanism right
for Roco LINE turnouts without bedding.

40297



Manual turnout mechanism left
for Roco LINE turnouts without bedding.

40298



Manual turnout mechanism right
for Roco LINE turnouts without bedding.

10030



Below baseboard turnout mechanism can be used for all Roco rail systems. Low energy consumption, shut off mechanism, 4 single-pole double-throw switches. Can also be installed horizontally. Dimensions approx. 60 x 27 x 45 mm

40293



Below baseboard set of lanterns to match general purpose below baseboard propulsion mechanism 10030 (optionally DB or SBB) and coupled 90° rotation. Use only for turnouts without bedding.

40292

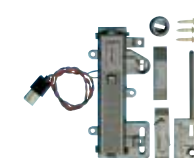

General purpose beneath board uncoupler
Suitable for later mounting for all two-rail DC track systems. Size of the propulsion unit: approx. 80 x 40 x 15 mm

42605



Sleeper Roco LINE. With built-in reed switch, to be actuated by means of a 42256 magnet. This potential-free switching contact can be installed at any point of a track layout.

42256

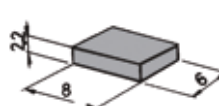

Magnets to trigger the 42605 and 61193 sleeper. Very small construction, therefore can easily be mounted beneath any vehicle. 6 pc./pack

42613

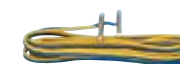

2-pole connecting cable. With mounted rail joiners for Roco LINE tracks. Only suitable for intermediate feeds due to insufficient cable cross-section. Cannot be used as the main connection of the model railway system!

42610



Rail joiners
24 pc./pack

42611



Plastic insulating rail joiners
24 pc./pack

42612



Transition rail joiners
Perfect for connecting FLEISCHMANN PROFIL track to Roco LINE track.

10000



Track fixing pins, short
For fastening tracks without roadbed, length 11.5 mm, approx. 400 pc./pack.

10001



Track fixing pins, long
For fastening GEOLINE and Roco LINE tracks with roadbed, length 15 mm, approx. 500 pc./pack.



98019

RP-25 frog inserts for ROCO LINE turnouts of the 10° system and ROCO LINE curved turnouts R5/R6.



98020

RP-25 frog inserts for ROCO LINE turnouts with branch angle of 15°.

RP-25: Uses for ROCO LINE tracks: While most NEM wheels have a flange height of about 1 mm, RP-25 wheels have a flange height of only 0.64 mm. If you run models with RP-25 wheels over the core pieces of standard turnouts, the jolts make the height difference noticeable. Inserts made of etched brass sheets allow rolling stock with RP-25 wheels to run smoothly.

40020

Main aspect signal



40021

Triplicated aspect signal of the SNCF



The signal is factory-equipped with the third, orange LED in conformity with the SNCF signal manual. Owing to the major difference in the meaning of the signal illustrations, please pay heed to the information in the operating instructions.



42267

Buffer stop (construction kit)

Optionally with wood plank or bumpers. For all gauge H0 track systems. Content: 1 piece



42608

Buffer stop (construction kit)

Prototypical stable construction for all gauge H0 track systems. Including 2 brake shoes to clip onto the rail. Content: 1 piece



42606

Rerailer

Rerailer makes it easier to place the vehicles on tracks. **For all gauge H0 track systems.**



42609

Wheel retracker set

Places derailed wheels back on track. **For GEOLINE and ROCO LINE tracks.** (Construction kit without track.)



10002

ROCO rubber

Track cleaning rubber; this special rubber is excellent for cleaning the rails of dirt and oil residue; suitable for all gauges.



10 x

10915

ROCO rubber, large package

Track cleaning rubbers 10002 in large packages containing 10 rubbers each.



40019

ROCO clean replacement wiper

ROCO clean replacement wiper for the H0 "ROCO clean" track cleaning wagon 46400.

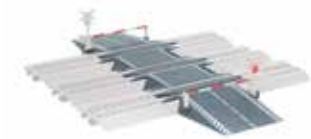

40022

Railway crossing construction kit

Without tracks. Can be used for 1, 2 or 3-track level crossings.



Photo: Josef Kaufmann, Club "Freunde der Mariazellerbahn Modell"

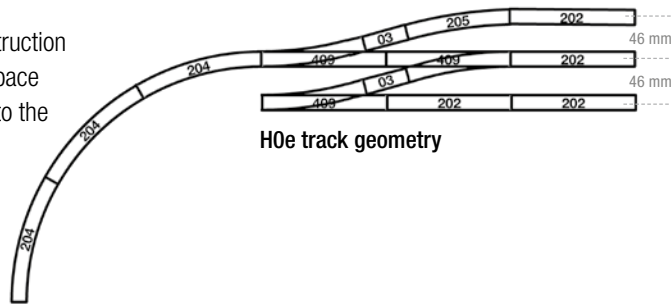

Photo: Josef Kaufmann, Club "Freunde der Mariazellerbahn Modell"

H0e tracks

Advantages:

- Simple and robust construction
- Doesn't require much space
- Visual appearance true to the original



Due to the reduction in scale, the ROCO H0e narrow gauge tracks have the same gauge as N tracks (9 mm). Arrangement, design and dimensions of the sleepers correspond exactly to the ones of the narrow gauge railway 750-/760-mm prototype. The light railway tracks also have a gauge of 9 mm. True to the original, the distances between the sleepers are even bigger here. The design of the individual sleepers corresponds to the roughly worked wooden planks that are often used with light railways.

For the operation of your light or narrow-gauge railway we would like to recommend our ROCO switching accessories.

Narrow-gauge tracks

32200

Flexible track

Length 730 mm, gauge: 9 mm.



32210

Sleeper end piece

matches H0e track 32200.



32409

Turnout left, without turnout mechanism.

Length of the straight track 134.4 mm (standard length), branch angle 15°, gauge: 9 mm.

Suitable motor: 32418 or 10030.

Turnout frog can be polarised if used with below baseboard mechanism.



32411

Turnout right, without turnout mechanism.

Length of the straight track 134.4 mm (standard length), branch angle 15°, gauge: 9 mm.

Suitable motor: 32419 or 10030.

Turnout frog can be polarised if used with below baseboard mechanism.



Accessories



32418

H0e/TT left turnout mechanism



32419

H0e/TT right turnout mechanism

Turnout mechanisms, suitable for all H0e turnouts double spool drive with shut-off mechanism. Can be used as replacement as well as for later upgrading of manual/under-baseboard turnouts.

Light railway tracks

32202

Straight track

Length 134.4 mm (standard length), gauge: 9 mm.



32201

Flexible light railway track

Length 730 mm, gauge: 9 mm.



32203

Straight track

Length 47.9 mm, gauge: 9 mm.



32211

Sleeper end piece

matches light railway flex track 32201.



32204

Curved track 30°

Radius 261.8 mm (standard radius), arc angle 30°, gauge: 9 mm.



32401

Light railway turnout, left, with electric drive

Length of the straight track 104.2 mm, branch angle 24°, radius of the branch track 194.6 mm, gauge: 9 mm.

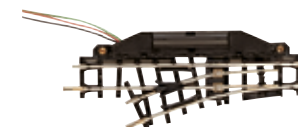

32205

Curved track 13,1°

Radius 493 mm, arc angle 13.1°, gauge: 9 mm. Opposite curve for narrow gauge turnouts.



32403

Light railway turnout, right, with electric drive

Length of the straight track 104.2 mm, branch angle 24°, radius of the branch track 194.6 mm, gauge: 9 mm.



Accessories

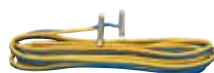

32417

H0e track connecting cable without radio suppression.



40390

H0e stirrup coupling
2 pc./pack

32413

H0e metal rail joiners (fishplate)
approx. 50 pc./pack



32414

H0e isolating rail joiners (fish-plate) approx. 24 pc./pack



96504

H0e wheel set

Insulated on one side, Ø 7 mm, Axle length: 13.85 mm. Individually orderable as spare parts

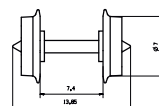

53711500

H0e wheel set

Insulated on one side, Ø 6,2 mm, Axle length: 13.85 mm. Individually orderable as spare parts

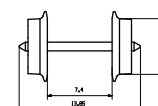

53714300

H0e wheel set

Insulated on both sides, Ø 5,1 mm, Axle length: 13.85 mm. Individually orderable as spare parts

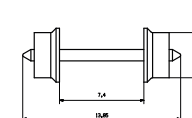

Electric turntable for gauge TT

With turntable switch.

35900

Comes with 6 ascent-descent tracks.
The maximum possible 24 ascent and descent tracks stand at an angle of 15° to each other.

Installation dimensions:

Required installation opening: 203 mm

Installation depth: 26.1 mm

External diameter of the turntable without track connections: 257 mm

Revolving platform length: 183 mm (locomotives with a wheel base length up to a 170 mm)

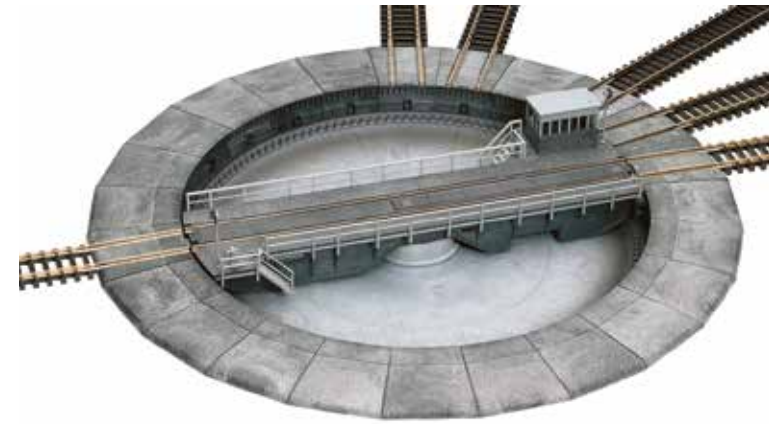

35901

Complementary set for the TT turntable

The set consists of 3 ascent/descent tracks.
A maximum of 24 tracks can be connected to the turntable.



30390

TT close-coupling

for NEM 358 standard socket.
2 pc./pack



30391

TT close-coupling

for NEM 358 standard socket.
50 pc./pack





Digital for beginners, Edition 1.1 - German

81385



What is a digital model railway and how can it be used best? This manual, edited by experts, answers the most important questions on the topic "How to digitize your own model railway layout". It provides both beginners and advanced users with valuable tips and tricks.

Digital for beginners, Part 2.1 - German

81386



If you are driving and controlling digitally with the Z21 multiMAUS, you already know the advances of the ROCO/FLEISCHMANN digital system. But how to enlarge your Starter Set, activate the wireless Z21 wlanMAUS, use tablet or smartphone for control or how to update your control units etc.

Digital for beginners, Part 3 - German

81393



In the digital age, the computer can reduce all manual work. If you still are operating your trains manually and set your points by mouse click then this book is just the right thing for you. We will help you to set up the interlocking systems and to create the connection with your layout.

Digital for beginners, Part 1 - English

81391

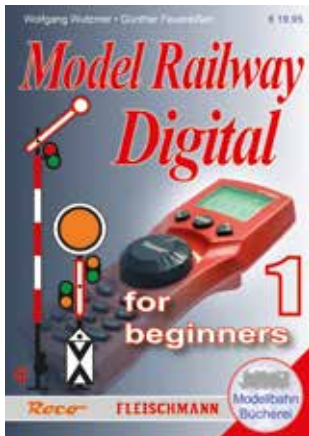

This manual in English language, edited by experts, answers the most important questions on the topic "How to digitize your own model railway layout". Layout construction, programming and other functions are shown and explained here step by step.

ROCO LINE track plans H0 - German

81394



This manual, edited by experts, depicts a large number of track plans that perfectly match the ROCO LINE track system. It provides the user with clear and comprehensive information about how to easily build challenging track aspects and railway layouts using the matching part lists.

GEOLINE track plans H0 - German

81397



This manual offers various options and gives tips how to easily build and plan a model railway. This starts with finding a suitable motive, practical ideas for the step by step structure and leads to the creation of a matching track plan.

Signals - Setup and connection - German

81392

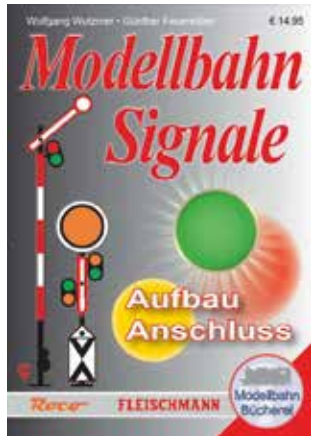

This brochure explains the main electrically-powered model signals, shows you the prototypical installation location and gives specific tips on how to set them up for analog or digital switching, from block diagrams to the switching signals and rail crossings.

Building and maintenance for beginners - German

81388

Q2/2023

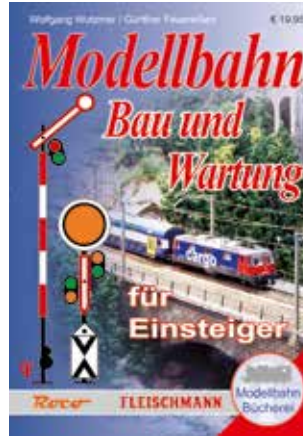

There is neither a patent recipe, nor a quick solution when you want to build your model railway layout at the weekend. We are happy to support you with many practical examples and tricks and hints, so you can easily build your individual layout. We are proud to help you to understand the technical conditions and how to cope with the maintenance of your vehicles and putting them into operation.

Operate and switch for beginners - German

81389



This brochure will help you to operate and connect your model railway layout. Locomotives, trains, switches, signals, gates and all sorts of accessories – everything is kept moving, everything is put into operation by electricity.

Step by step and almost playfully you will learn how to face the electrical challenges of your layout and to solve all your problems.



Content	10636	21	10869	10	35900	60	40183	28	40322	24	
6516	26	10637	21	10870	10	35901	60	40184	28	40326	26
6560	28	10638	21	10887	18	40000	31	40186	28	40343	25
6561	28	10723	21	10889	18	40001	31	40187	28	40344	25
6562	28	10726	21	10890	18	40004	31	40188	28	40345	26
6563	28	10749	21	10891	18	40005	31	40189	28	40360	24
05216	32	10753	15	10892	18	40014	31	40190	28	40361	24
05217	32	10754	15	10893	19	40019	56	40191	29	40375	26
10000	55	10756	15	10894	19	40020	56	40192	29	40376	26
10001	55	10757	15	10895	19	40021	56	40193	29	40390	26/59
10002	56	10758	15	10896	19	40022	56	40194	29	40395	25
10003	31	10789	14	10900	31	40025	32	40195	29	40396	25
10019	23	10797	13	10905	31	40026	32	40196	29	40397	25
10030	55	10798	21	10906	31	40066	29	40197	29	40411	26
10520	22	10804	13	10908	31	40067	29	40198	29	40420	24
10521	22	10805	13	10915	56	40068	29	40199	29	40500	31
10522	23	10806	13	30390	60	40069	29	40243	26	40501	31
10524	22	10807	13	30391	60	40070	29	40244	26	42010	44
10525	22	10808	13	32200	58	40071	29	40264	29	42011	44
10526	23	10813	8	32201	59	40072	29	40266	29	42012	44
10602	21	10814	9	32202	59	40073	29	40267	29	42013	44
10603	21	10818	9	32203	59	40074	29	40270	25	42256	55
10605	21	10819	13	32204	59	40075	29	40271	25	42267	56
10608	21	10820	8	32205	59	40076	29	40281	25	42400	45
10616	21	10833	9	32210	58	40077	29	40286	25	42401	45
10619	23	10834	9	32211	59	40080	32	40287	25	42406	46
10623	21	10835	8	32401	59	40081	32	40292	55	42408	47
10625	21	10836	11	32403	59	40082	32	40293	55	42409	47
10628	21	10837	11	32409	58	40160	31	40295	55	42410	46
10630	21	10838	11	32411	58	40177	28	40296	55	42411	46
10631	21	10850	13	32413	59	40178	28	40297	55	42412	46
10632	21	10850	14	32414	59	40179	28	40298	55	42413	46
10633	21	10851	14	32417	59	40180	28	40314	25	42419	46
10634	21	10857	14	32418	58	40181	28	40317	25	42421	46
10635	21	10859	14	32419	58	40182	28	40321	24	42422	47

42423	47	42519	38	42608	56	101365	24
42424	47	42521	38	42609	56	101366	24
42425	47	42522	39	42610	55	109088	24
42426	47	42523	39	42611	55	136100	15
42427	47	42524	39	42612	55	386516	26
42428	47	42525	39	42613	55	670601	21
42430	47	42526	39	42615	52	53711500	59
42440	48	42527	39	42616	52	53714300	59
42441	48	42528	39	42617	52		
42448	48	42530	39	42620	54		
42451	48	42532	40	42624	54		
42454	48	42533	40	42650	54		
42464	50	42543	40	42651	54		
42465	50	42546	40	42652	54		
42470	51	42549	41	42653	54		
42471	51	42556	42	42660	45		
42472	50	42557	42	42661	45		
42473	50	42568	43	46807	31		
42476	51	42569	43	81385	62		
42477	51	42570	43	81386	62		
42488	49	42571	43	81388	63		
42489	49	42572	42	81389	63		
42493	49	42573	42	81391	62		
42496	49	42580	41	81392	63		
42497	48	42581	41	81393	62		
42498	49	42591	41	81394	62		
42506	38	42594	40	81397	62		
42508	39	42597	41	82111	31		
42509	39	42598	41	93517	24		
42510	38	42600	45	93518	24		
42511	38	42601	45	93728	24		
42512	38	42602	54	93733	24		
42513	38	42603	54	96504	59		
42517	38	42605	55	98019	56		
42518	38	42606	56	98020	56		



Published by:

Modelleisenbahn GmbH
Plainbachstraße 4, 5101 Bergheim; Austria
www.roco.cc

Photo credits:

Modelleisenbahn GmbH, M. Zim, S. Zenzmaier, H. Auer, M. Huber, H. Gogg as well as other photographers that are credited next to the pictures.
Cover background: R. Scheiwiller at Pixabay

Printing and processing:

Walstead Leykam Druck GmbH & Co KG, Bickfordstraße 21, 7201 Neudörfel, Austria

Copyright:

© 2022 Modelleisenbahn GmbH. All rights reserved.

This catalogue including all its components such as data or images are protected by copyright law. Any use beyond the narrow confines of the copyright law without the consent of the Modelleisenbahn GmbH is prohibited and liable to prosecution. This applies in particular to reproductions, translations, archiving on microfilm and the use and further processing in any electronic systems. The copying of the trade descriptions, trade brands, trade names or company names and other characteristics in this catalogue does not justify the assumption that those can be used by everybody free of charge. It can rather be that they are registered trademarks or characteristics otherwise protected by law, even if these are not specifically marked up as such.

® Registered trademarks: ROCO, FLEISCHMANN, FLÜSTERSCHLEIFER, ROCO LINE, GEOLINE, Z21, multiMAUS, smart RAIL

Trademark owner: Modelleisenbahn GmbH, Plainbachstrasse 4, 5101 Bergheim; Austria

Article 10, 10a Trademark Protection Act (Gem. §§ 10, 10a MarkenSchG) entitles the trademark owner to prevent all third parties, who do not have his consent, from using in the course of trade the registered trademarks mentioned above.

The third-party brands RailCom* and Motorola** used by us are stated - as explained here - with the corresponding meaning.

* RailCom is a registered trademark of Lenz Elektronik GmbH, Gießen

** Motorola is a registered trademark of Motorola Inc., Schaumburg, Illinois, US

Liability:

The Modelleisenbahn GmbH strives to provide the content of this catalogue with the highest quality. Despite of our best effort and the best possible care, the Modelleisenbahn München is not liable and gives no warranty for the accuracy, the up-to-dateness of completeness of the contents and the information given in this catalogue. For eventual damages of material or immaterial nature that result from the use, the non-use or the withholding of faulty or incomplete information in this catalogue – as far as it is not founded in demonstrable intent and gross negligence on behalf of the Modelleisenbahn GmbH – no guarantee or liability can be accepted. The Modelleisenbahn GmbH reserves the right to update the contents of the catalogue as well as the technical specifications of the contained products at any time.

Many models shown on the illustrations are photomontages and CAD drawings. The final and delivered version of the models may therefore differ from the depicted illustrations. Electrical and mechanical data and dimensions may vary. Products from the series production may differ in detail from the depicted models. It may be possible that the depicted or described products in the catalogue are not available in your country. Availability and delivery options of the illustrated products are subject to change.



Roco

Modelleisenbahn GmbH
Plainbachstraße 4
5101 Bergheim • Austria
www.roco.cc

Your ROCO retailer

81843

